

NEWS 2026

Plankfist

Poliform

of the home - from the living room to the bedroom, from the kitchen to outdoor spaces. It is designed by Jean-Marie Massaud and Emmanuel Gallina, joined for the first time by the New York-based studio Yabu Pushelberg, bringing a fresh perspective to the brand's lifestyle vision. Three new lamps by studioutte expand the lighting collection, taking Plankfist's design focus into the world of indoor and outdoor lighting.

2026

COLLECTIONS

INDOOR HOME COLLECTION	9
INDOOR KITCHEN COLLECTION	291
OUTDOOR COLLECTION	311

INDOOR HOME COLLECTION

The new indoor collection introduces new styles and design languages. In the living area, the contemporary comfort of modernist-inspired sofas gives way to the elegant forms of the dining area, while armchairs and chaise longues with bold lines contrast with the kitchen's softer forms. The new

integrating new functions both in the sleeping area and in the wardrobe. Featured across all interiors are two new lamps, style accents that help define a cohesive and complete vision of the home.

INDOOR HOME COLLECTION

SAVOY SOFA	13
SAVOY COFFEE TABLE	49
ALFRED ARMCHAIR	57
ATTIMO CHAISE LONGUE	71
ORBIS LOUNGE ARMCHAIR	81
ADRIEN COFFEE TABLE	91
JOAN COFFEE TABLE	101
VORTICE TABLE	113
AUGUSTE CHAIR	127
NEO CONCORDE TABLE	141
VICTORIA CHAIR	161
LANAI BED SYSTEM	171
LANAI NIGHT COMPLEMENTS	183
AQUALUNA ARMCHAIR	191
LANAI COFFEE TABLE	205
LANAI SIDEBOARD	211
SUITE ISLAND	219
NIGHT SYSTEM ACCESSORIES	229
HUGO LAMP	239
KLARA LAMP	245
NEW INDOOR FABRICS	251
INDOOR PROPOSALS	257
TECHNICAL DATA	279

SAVOY SOFA

In the Savoy sofa, Jean-Marie Massaud combines geometric purity and softness, creating a structure of comfort that lends itself to generous configurations for the most spacious living areas. The reference to modernist design lies in the idea of making the structure that supports the generous cushions visible. Linear and modular, Savoy redefines the domestic landscape, striking a perfect balance between protection and relaxation.







This and next pages: Savoy sofa with removable cover in fabric Carnegie 02 lino, cushions in fabric Carnegie 02 lino, back structure of the sofa in glossy lacquer carbone, mat brown nickel feet. Previous pages: Savoy sofa with removable cover in fabric Bolshoi 58 bianco, cushions in fabric Bolshoi 58 bianco, back structure of the sofa in glossy lacquer carbone, mat brown nickel feet.



This page: close up of the Savoy sofa with removable cover in fabric Carnegie O2 lino and sofa back structure in glossy lacquer carbone.







This and next page: Savoy sofa with removable cover in leather Nabuk 04 moka, cushions in leather Nabuk 04 moka, back structure of the sofa in glossy lacquer carbone, mat brown nickel feet.



This and next page: Savoy sofa with removable cover in leather Nabuk 04 moka, cushions in leather Nabuk 04 moka, back structure of the sofa in glossy lacquer carbone, mat brown nickel feet.







This and next page: Savoy sofa with removable cover in fabric Bolshoi 58 bianco, cushions in fabric Bolshoi 58 bianco, back structure of the sofa in glossy lacquer carbone, mat brown nickel feet.



This and next page: Savoy armchair with removable cover in leather Ermitage 03 cognac, sofa back structure in black elm, mat brown nickel feet.





This and next page: Savoy armchair with removable cover in fabric Carnegie 01 bianco, sofa back structure in black elm, mat brown nickel feet.





SAVOY

seduta in poliuretano a quote differenziate, priverivestimento in tela cotone e piuma. Cuscini opzionali in tela cotone e piuma.

nickel opaco.

Structure in wood and wood derivatives. Backrest and seat in polyurethane with differentiated densities, pre-cover in cotton canvas and down. Optional cushions in cotton canvas and down. Back structure of the sofa in black elm or glossy lacquer carbone. Feet in mat brown nickel painted metal. Removable cover in fabric or leather.

**Divano composto
Modular sofa**

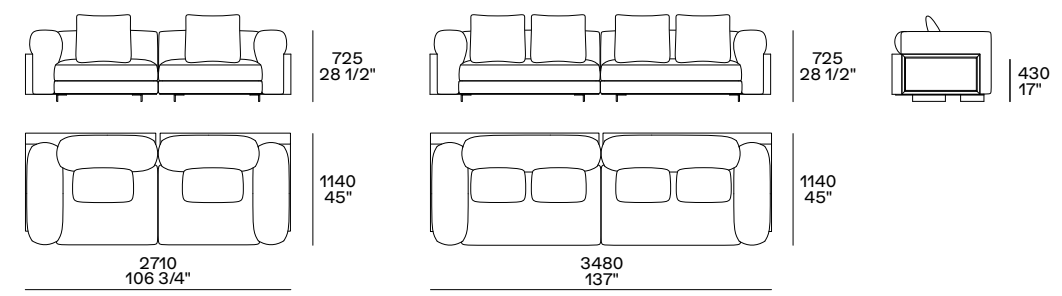

**Cuscino opzionale
Optional cushion**

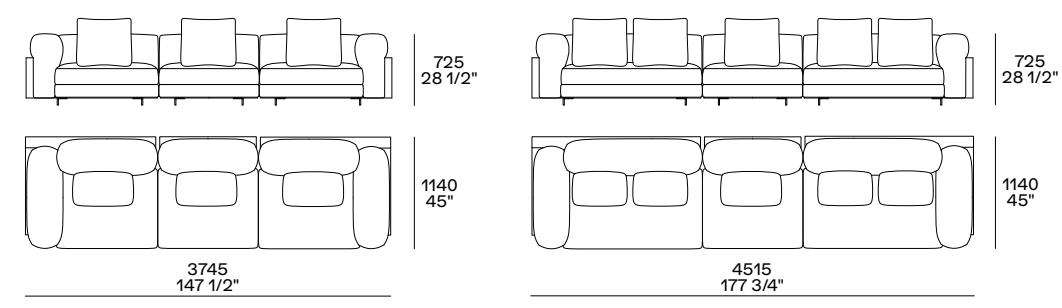
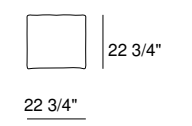

**Divano composto senza retrodivano
Modular sofa without back structure**

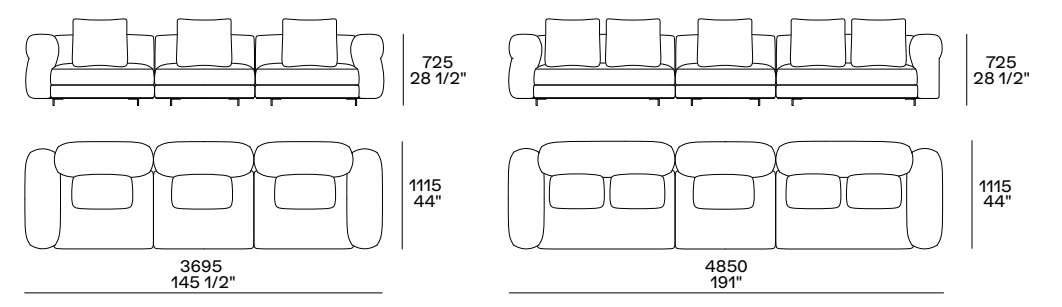
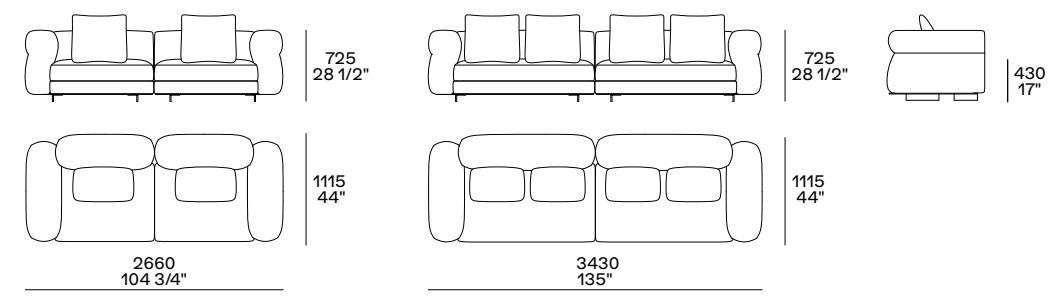

**Terminale sx-dx
Lt-rt end unit**

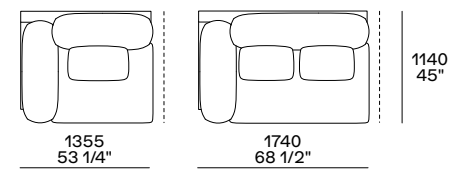

**Terminale penisola sx-dx
Lt-rt peninsula end unit**

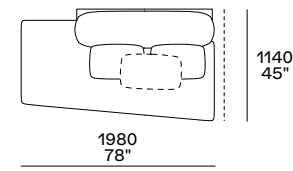

**Terminale penisola inclinato sx-dx
Lt-rt angled peninsula end unit**

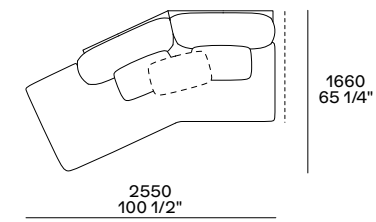

**Angolo sx-dx
Lt-rt corner unit**

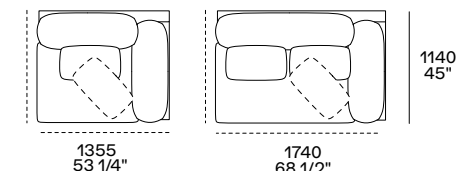

**Angolare inclinato sx-dx
Lt-rt angled corner unit**

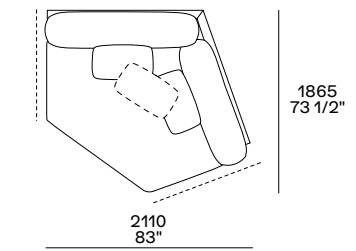

also used as lt-rt angled end unit

**Terminale sx-dx senza retrodivano
Lt-rt end unit without back structure**

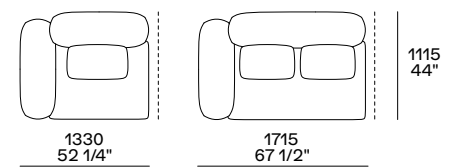

**Terminale penisola sx-dx senza retrodivano
Lt-rt peninsula end unit without back structure**

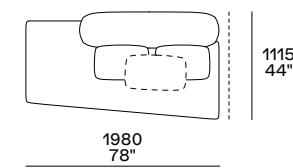

**Terminale penisola inclinato sx-dx senza retrodivano
Lt-rt angled peninsula end unit without back structure**

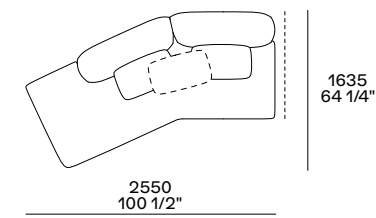

**Angolo sx-dx senza retrodivano
Lt-rt corner unit without back structure**

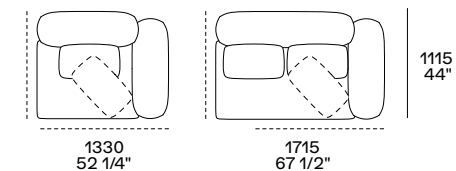

**Angolare inclinato sx-dx senza retrodivano
Lt-rt angled corner unit without back structure**

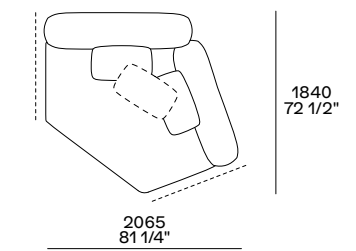

also used as lt-rt angled end unit

**Centrale
Central unit**

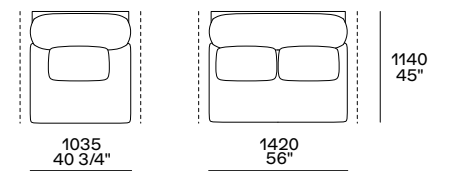

**Centrale inclinato
Angled central unit**

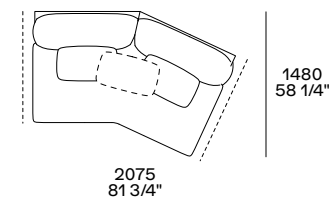

**Centrale senza retrodivano
Central unit without back structure**

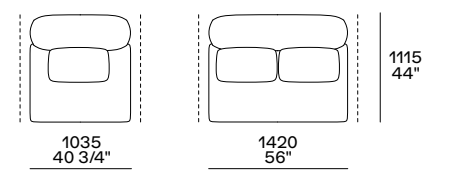

**Centrale inclinato senza retrodivano
Angled central unit without back structure**

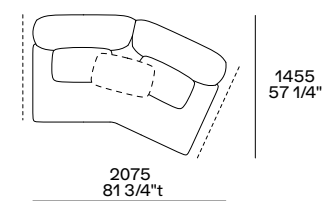

**Chaise longue sx-dx
lt-rt Chaise longue**

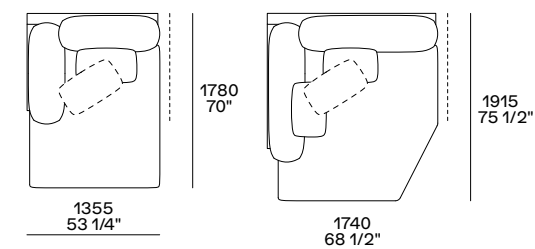

**Chaise longue inclinata sx-dx
lt-rt angled chaise longue**

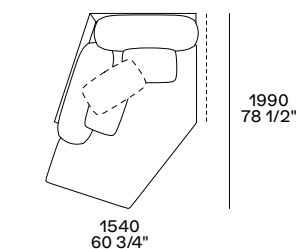

**Poltrona
Armchair**

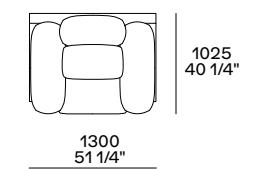

**Chaise longue sx-dx senza retrodivano
lt-rt chaise longue without back structure**

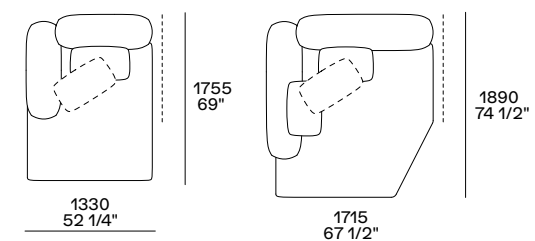

**Chaise longue inclinata sx-dx senza retrodivano
lt-rt angled chaise longue without back structure**

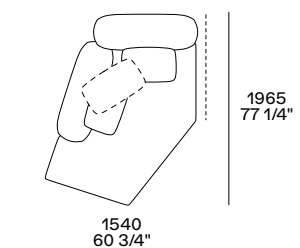

**Poltrona senza retrodivano
Armchair without back structure**

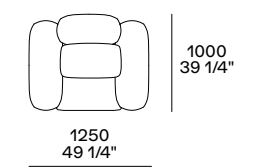



SAVOY COFFEE TABLE

Like the sofa, the Savoy coffee tables also stem from a search for balance between geometric purity and softness. Resting on the structure are round tops in glass or marble with beveled edges, creating a pleasing visual and tactile effect.



This and previous pages: Savoy coffee table with structure in satin-finish brown nickel, top in fused glass bosco and mat nero marquina marble polyester finish. Next page: Savoy coffee table with satin-finish brown nickel structure, top in mat nero marquina marble polyester finish.





SAVOY

Design Jean-Marie Massaud

nickel satinato.
Piano in vetrofusione nei colori bosco, fume e bronzato o in marmo levigato e lucido.

Structure in satin-finish brown nickel painted metal.
Top in fused glass in the colours bosco, fume and bronzato or in mat and glossy marble.

Piano in marmo Top in marble

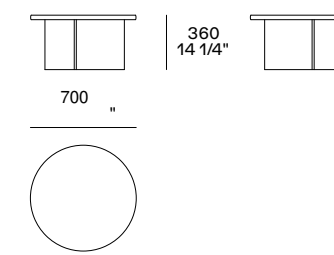
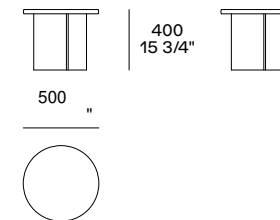

Piano in vetro Top in glass

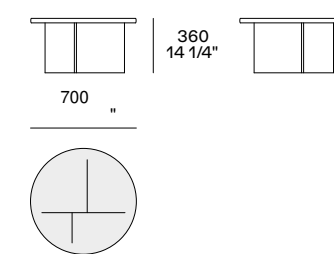
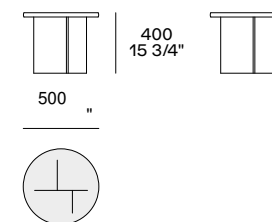

ALFRED ARMCHAIR

With its informal design, the Alfred armchair expresses both boldness and elegance. Though conceived as a single piece - a soft volume upholstered in leather or fabric - it retains the presence of the classic lounge armchair, embodying a contemporary lifestyle centred on the pursuit of comfort.

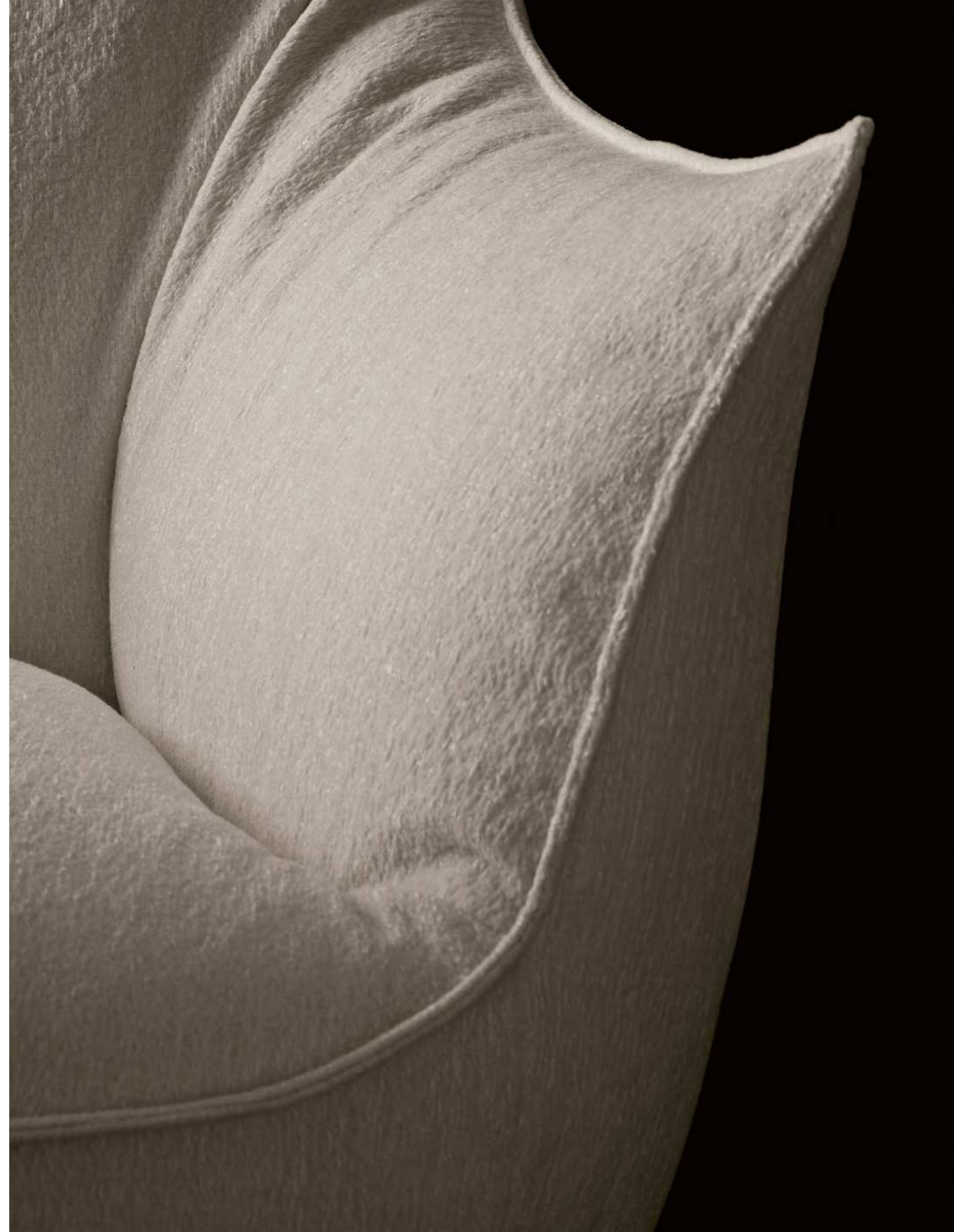



This page: close up of the Alfred armchair with removable cover in leather Ermitage 07 carbone. Previous pages: Alfred armchair with removable cover in fabric Bolshoi 58 bianco.



This page: Alfred armchair with removable cover in leather Ermitage 07 carbone.



This and next page: Alfred armchair with removable cover in leather Nabuk 01 latte.





ALFRED

o pelle, prriverestimento in piuma.
Base in pannello di fibra ad alta densita
laccato carbone o base girevole in metallo.

seat in fabric or leather, pre-cover in down.
Base in high-density fiberboard lacquered
carbone or swivel base in metal.
Removable cover in fabric or leather.

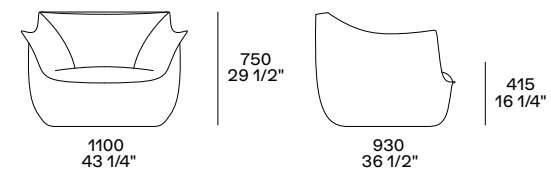

ATTIMO CHAISE LONGUE

An elegant, curved structure cradles a soft filled cushion, of-

Attimo chaise longue draws inspiration from the archetype of the African chair - essential, light and fluid - reimagined with comfort and modernity in mind. In the version upholstered in fine aniline leather, the seat celebrates the authenticity of the material, with its natural grain and a refined sensory quality that invites one to savour the moment.





This and next page: Attimo armchair with removable cover in velvet Persia 1404 carbone and black elm structure. Previous pages: Attimo armchair with removable cover in leather Ermitage 07 carbone and black elm structure.



ATTIMO

metallo verniciato carbone. Seduta in

prerivestimento in tela cotone e fibra di poliestere. Rivestimento sfoderabile in tessuto o pelle.

Structure in black elm, feet in carbone painted metal. Seat in flexible polyurethane with differentiated densities, pre-cover in cotton canvas and polyester fiber. Removable cover in fabric or leather.

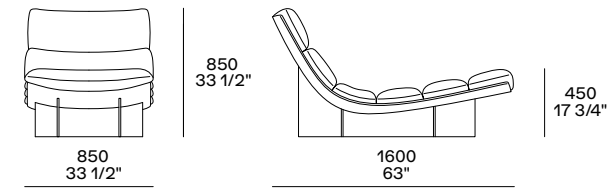

ORBIS LOUNGE ARMCHAIR

Orbis is a lounge piece with an enveloping form, a cocoon-like armchair defined by generous curves and elements designed for maximum comfort, such as the pouf and headrest. The soft seat creates a sense of intimacy and calm in both residential and contract environments, balanced by slender, finely crafted metal feet. A refined detail shared by all the pieces in the Orbis collection.





This and next page: Orbis Lounge armchair with removable cover in fabric Konik 01 bianco, swivel base in glossy dark sheer metal. Footrest pouf with removable cover in fabric Konik 01 bianco, feet in glossy dark sheer metal. Previous pages: Orbis Lounge armchair with removable cover in velvet Persia 26 nero, swivel base in glossy dark sheer metal. Footrest pouf with removable cover in velvet Persia 26 nero, feet in glossy dark sheer metal





ORBIS LOUNGE

o pelle.

aluminium casting. Removable cover in fabric or leather.

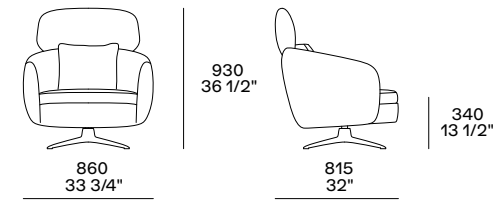

Pouf

Struttura in poliuretano flessibile monoquota, seduta in poliuretano flessibile a quote differenziate, priverestimento in tela cotone. Base fissa in fusione di alluminio verniciato opaco e lucido light sheer o dark sheer.

Pouf

Structure in flexible single-density polyurethane, seat in flexible polyurethane with differentiated densities, pre-cover in cotton canvas. Fixed base in glossy and mat light sheer or dark sheer painted aluminium casting. Removable cover in fabric or leather.

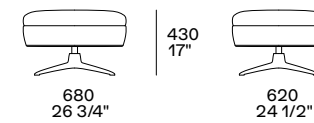

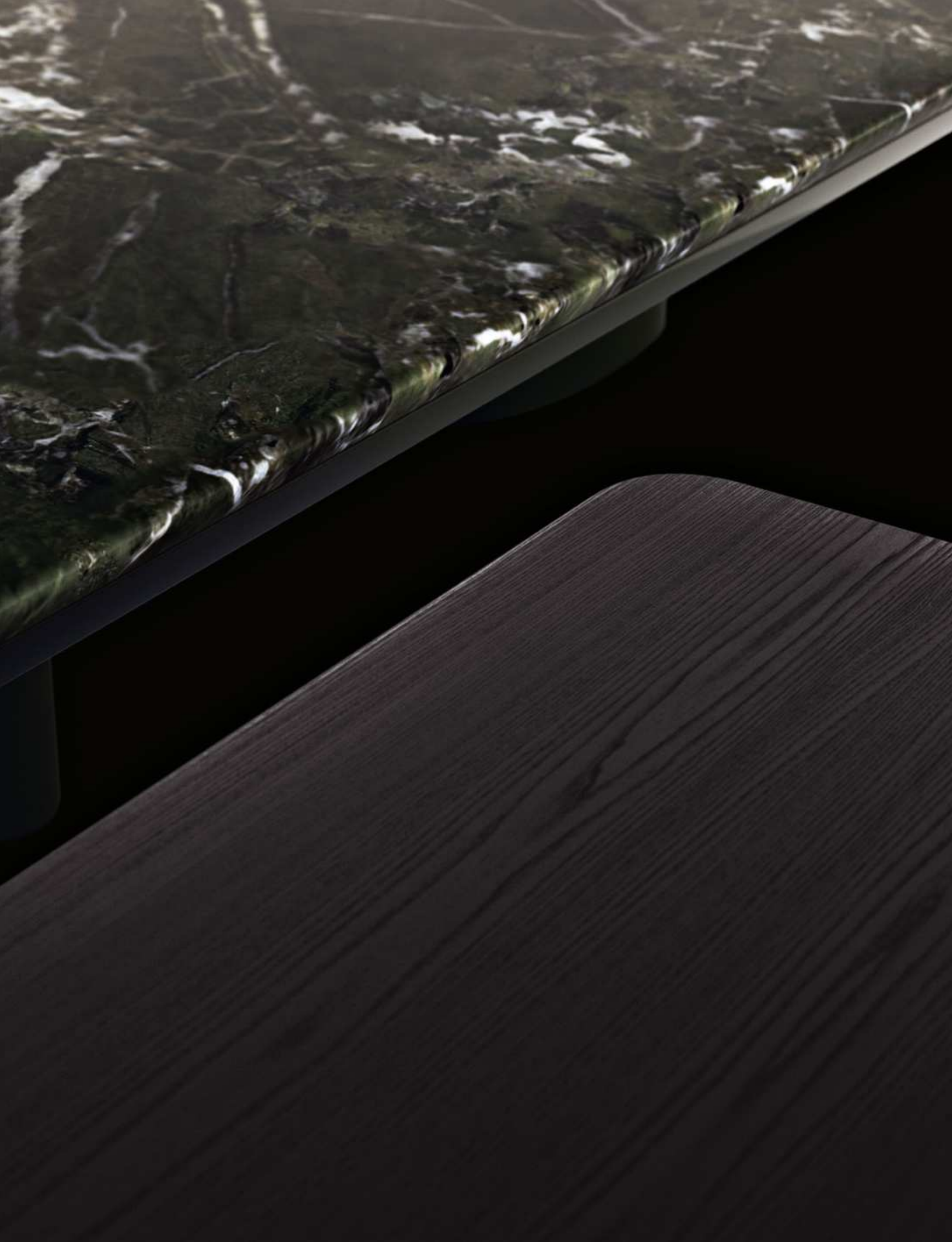

ADRIEN COFFEE TABLE

The Adrien coffee tables are now available in larger sizes. Designed for the most refined living spaces, these tables stand out for their generous proportions and versatility: they can be used individually or combined to create sophisticated, personalised compositions.



This and previous pages: Adrien coffee table with top in mat verde lepanto marble, structure in glossy lacquer tundra.



This and next page: Adrien coffee table in black elm.

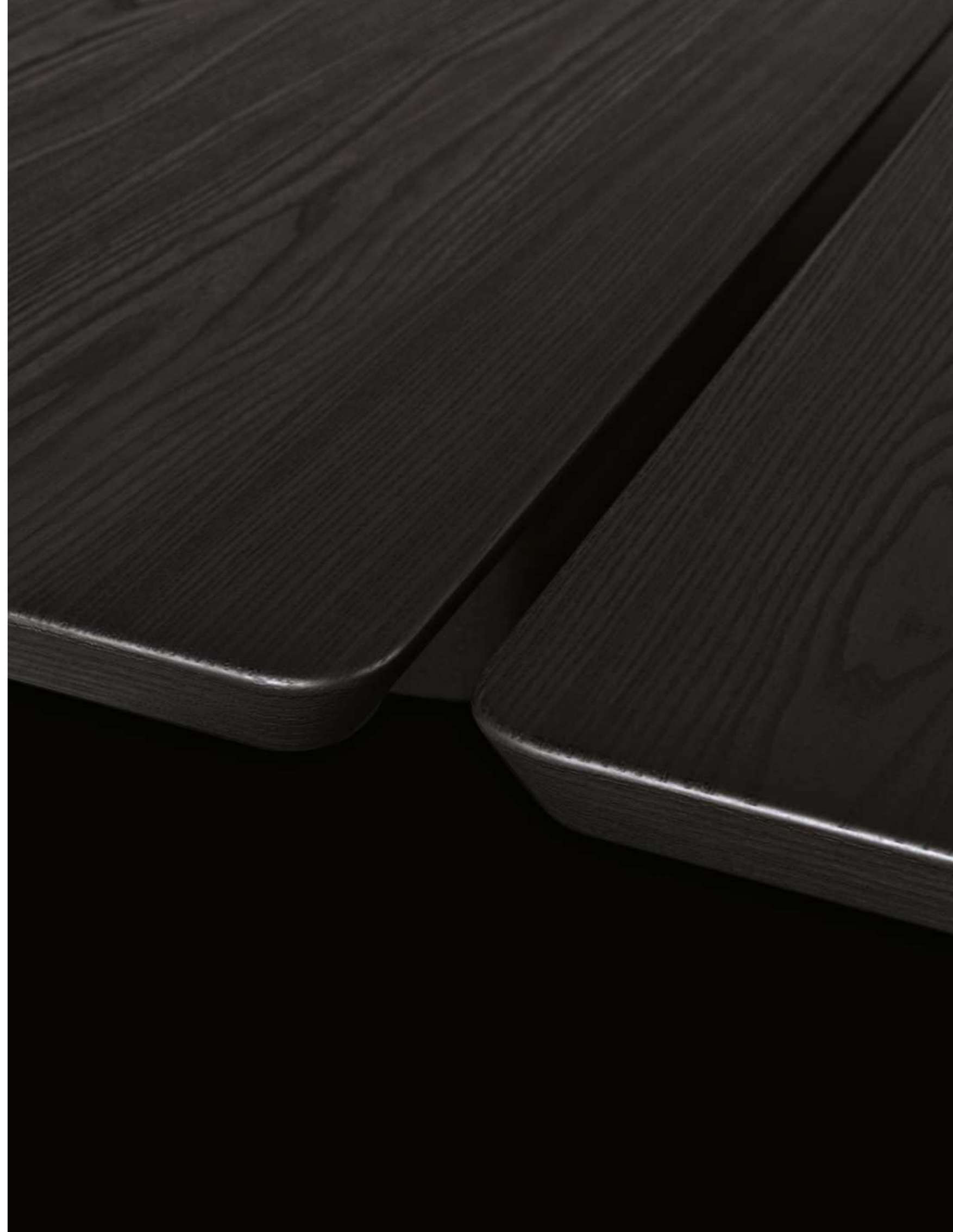

ADRIEN

verniciato opaco e lucido light sheer o dark sheer.

Structure in solid wood stained black elm, glossy lacquered colours metal or mat and glossy light sheer or dark sheer painted metal.

Top in glossy lacquered colours, black elm or mat and glossy marble (except travertino classico, travertino titanium and zecevo).

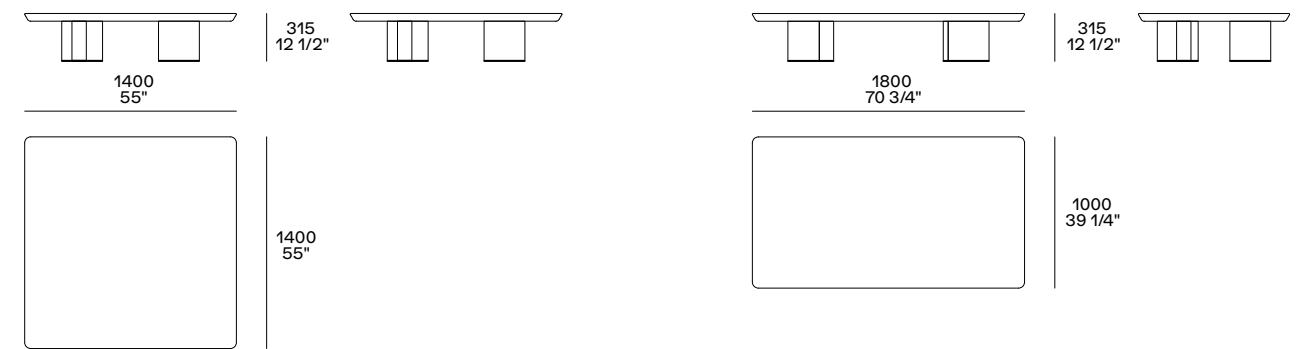

JOAN COFFEE TABLE

The Joan coffee tables are sculptural objects designed to complete refined interiors, used either as centrepiece elements or placed beside the sofa. Now available in an even wider range of sizes, they allow for unique compositions, ideal for contemporary interior design projects.



This and previous page: Joan coffee tables in glossy lacquer sella and glossy steel. Opening page: Joan coffee table in black elm.

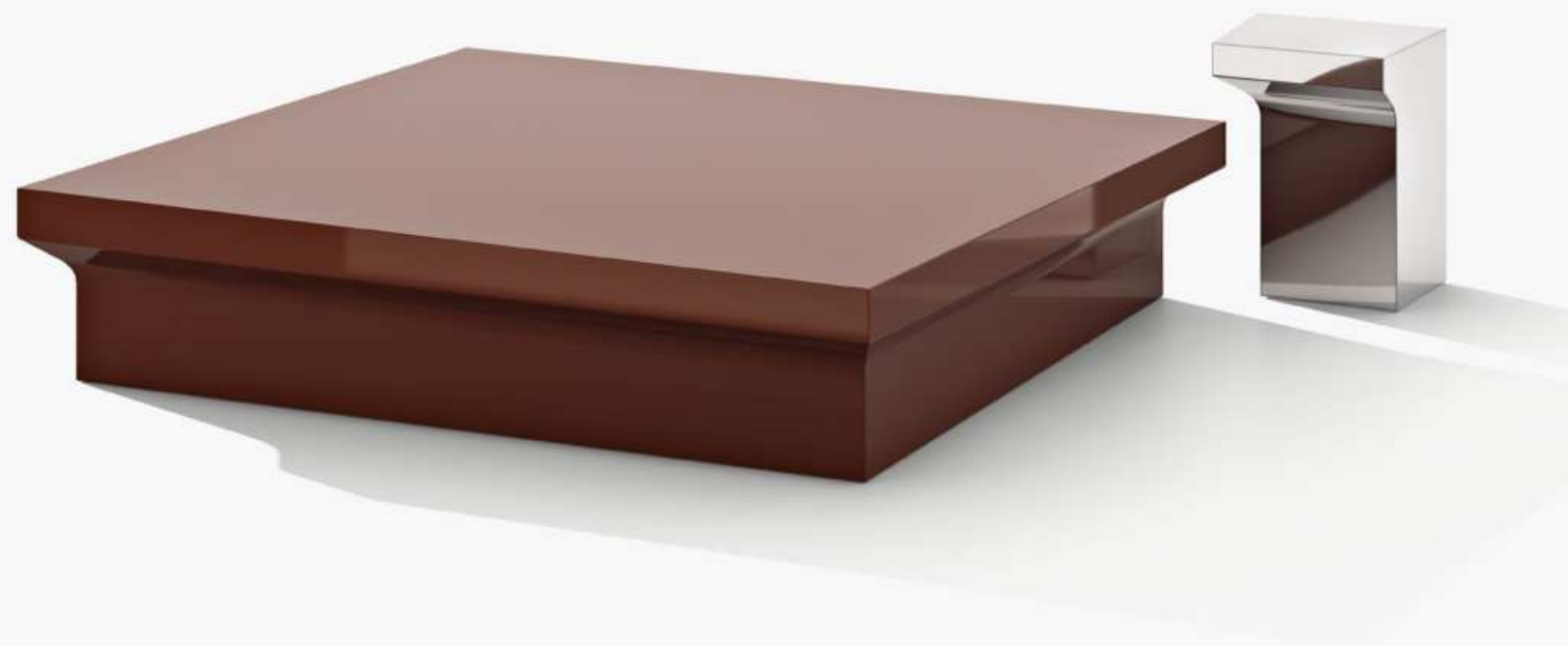

This and next page: Joan coffee tables in glossy lacquer carbone and black elm.



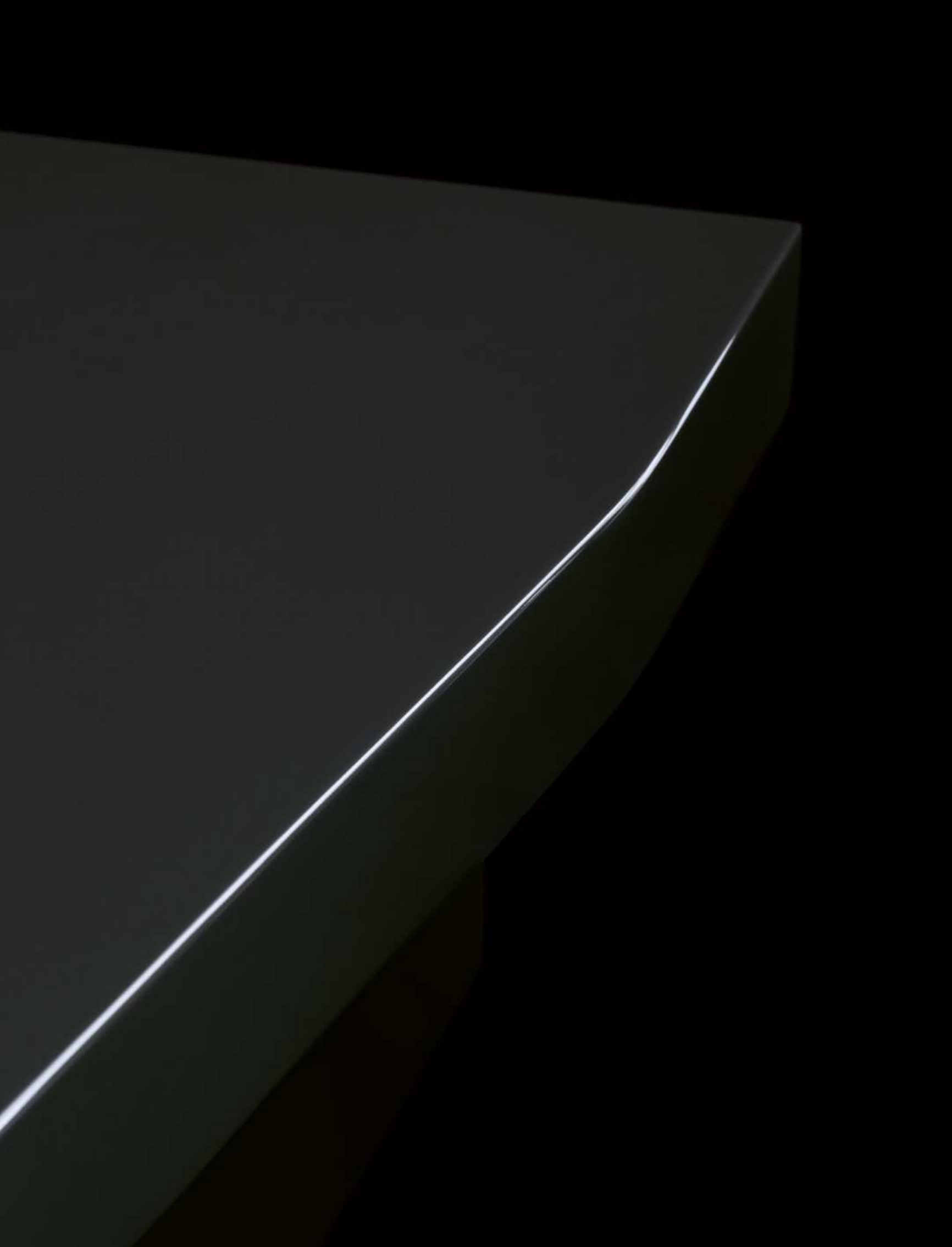

Next page: Joan coffee tables in black elm and glossy steel.



JOAN

acciaio lucido.

Structure and top in black elm, mat
lacquered colours, glossy lacquered colours
or glossy steel.

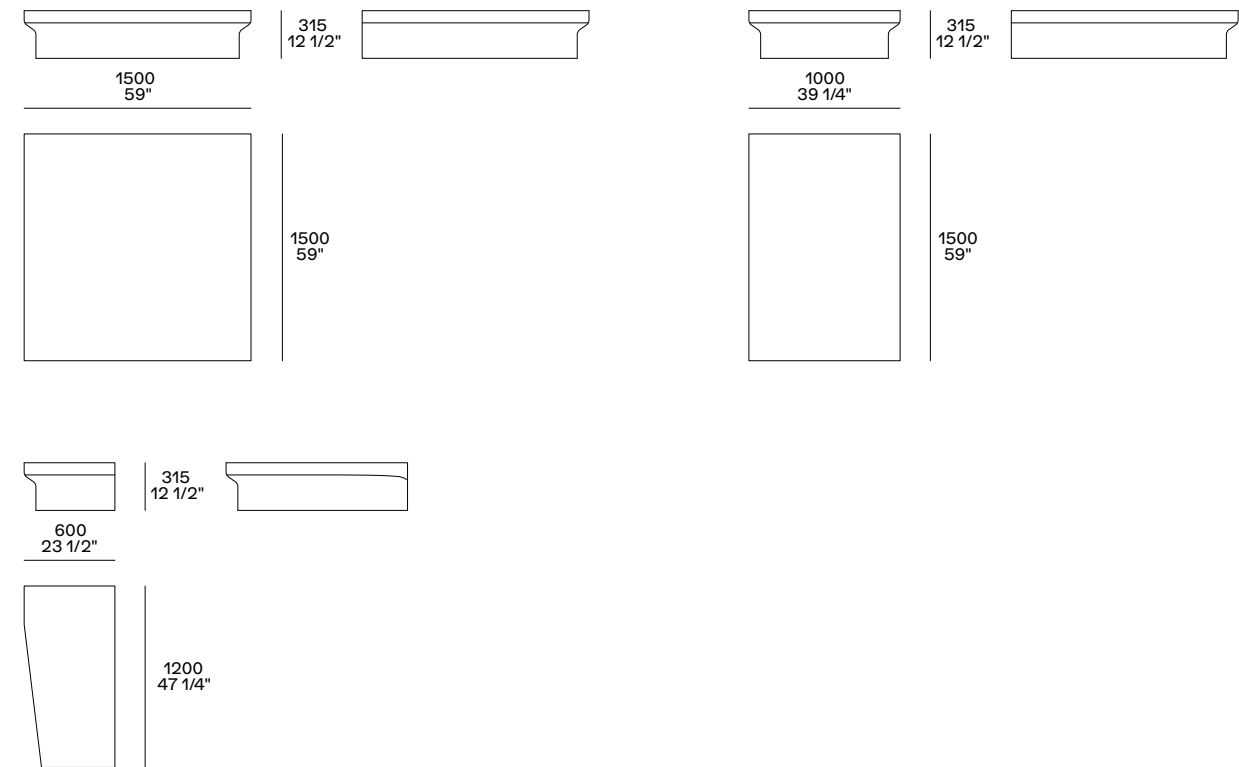

VORTICE TABLE

Vortice is a sculptural yet lightweight table. Designed for more compact spaces such as the kitchen, it reflects an innate elegance and a sophisticated spirit that respond to the needs of contemporary dining. The central metal base features a hand-crafted finish that enhances the authenticity of the material, especially when paired with marble or wood tops, always with bevelled edges.

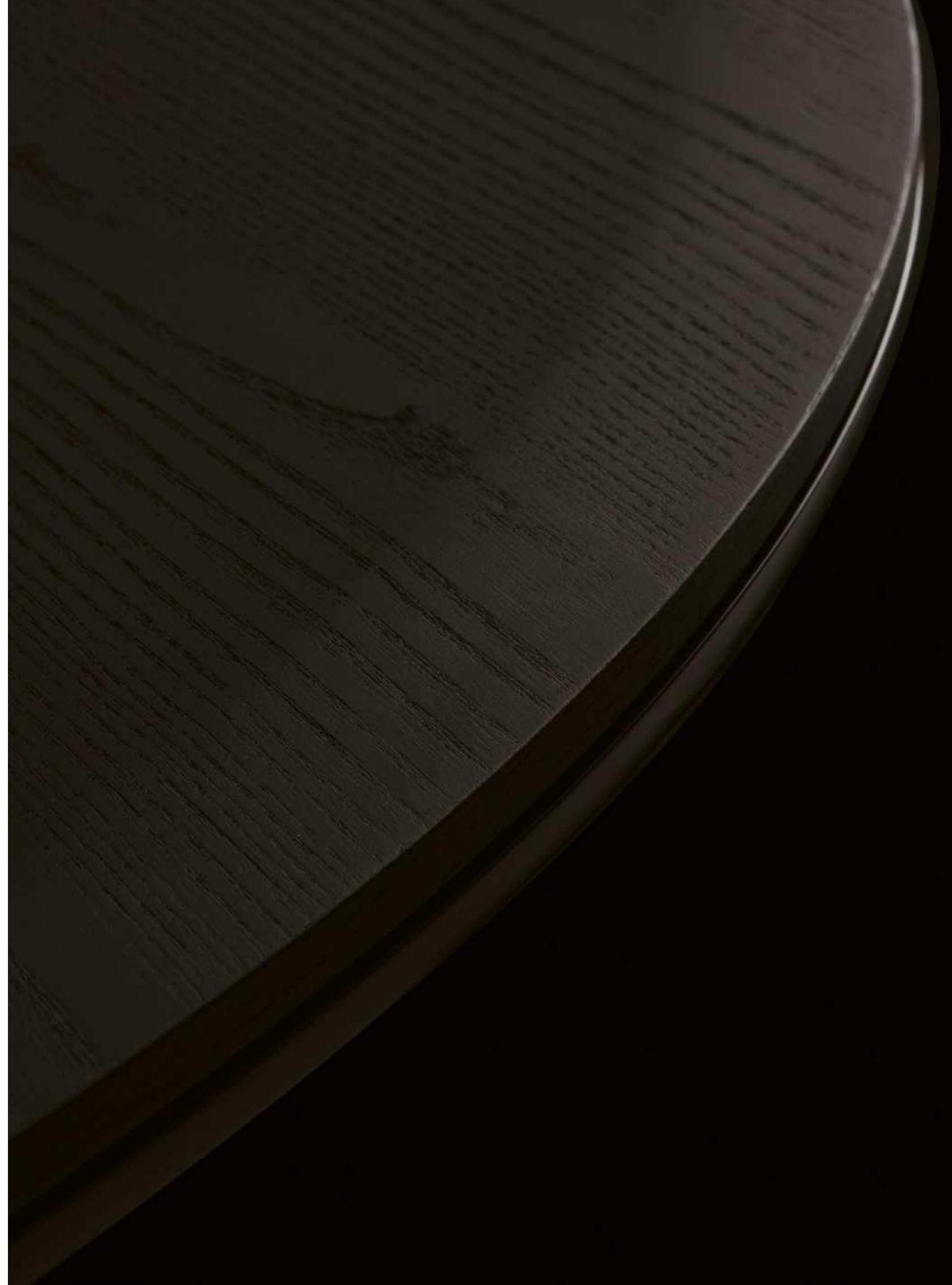



This page: close up of the Vortice table with structure in dark sheer raw and top in mat sahara noir marble polyester finish. Previous pages: Vortice table with structure in dark sheer raw and black elm top.



This page: Vortice table with structure in dark sheer raw and top in mat sahara noir marble polyester finish.



This and next page: Vortice table with structure in avorio mat painted metal and top in mat oyster white marble.





VORTICE

in appoggio, in laccato lucido e opaco

is available, placed on top, in glossy and mat lacquer, spessart oak, black elm or mat and glossy marble (except zecevo).

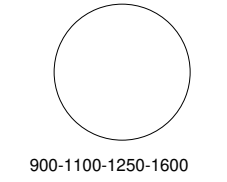
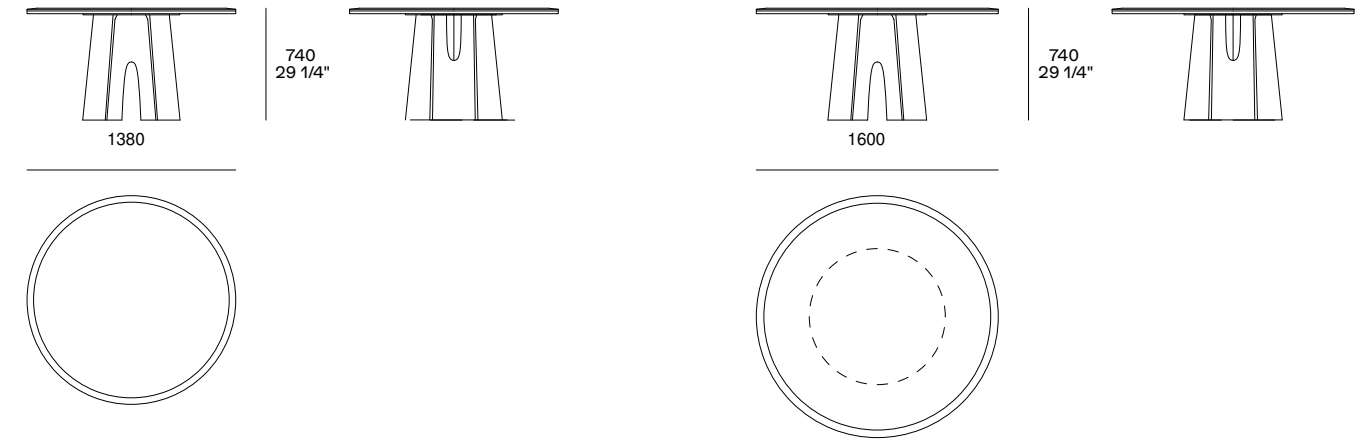

900-1100-1250-1600

vassoio girevole opzionale
optional swivel tray



AUGUSTE CHAIR

ic director's chair with a radical yet sophisticated attitude. Designed for the contemporary dining area, it presents a fresh, lightweight design that deliberately moves away from a traditional idea of elegance, also reflected in the choice of finishes such as metal and straw rope.





This page: close up of the Auguste chair with structure in avorio mat painted metal. Previous pages: Auguste chair with armrests, structure in satin-finish brown nickel, seat and backrest in synthetic straw.

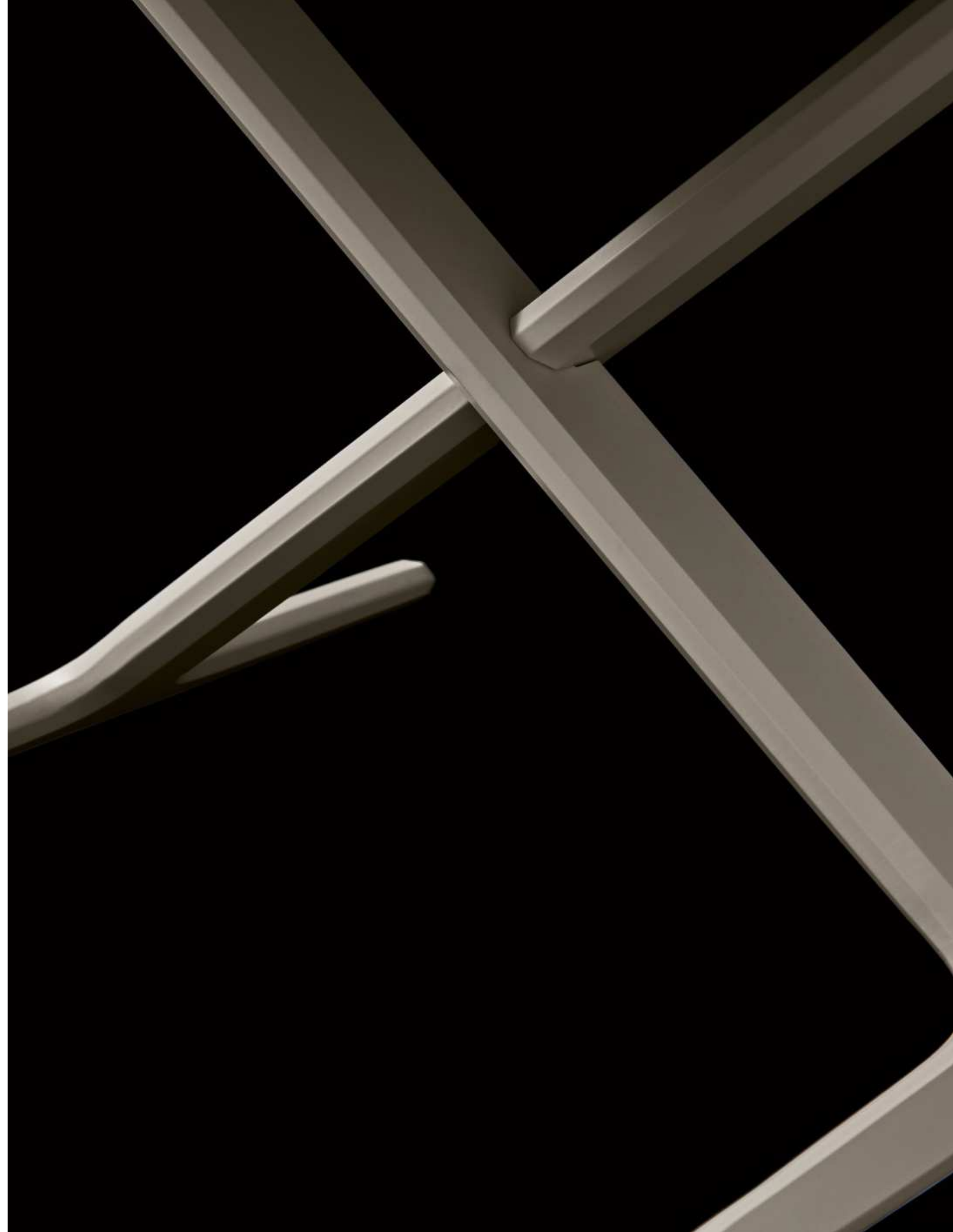

This page: Auguste chair without armrests, structure in avorio mat painted metal, seat and backrest in synthetic straw.



This and next page: Auguste chair without armrests, structure in satin-finish brown nickel, seat and backrest in non-removable leather Soft 12 moka.





AUGUSTE
Design Jean-Marie Massaud

o brown nickel satinato.
Schienale e seduta in poliuretano flessibile stampato monoquota o in paglia sintetica intrecciata. Prerivestimento in tela cotone

sfoderabile in tessuto, pelle o paglia sintetica.

Structure in avorio mat painted metal or satin-finish brown nickel.
Backrest and seat in single density moulded flexible polyurethane or in woven synthetic straw. Pre-cover in cotton canvas and polyester fiber. Non-removable cover in fabric, leather or synthetic straw.

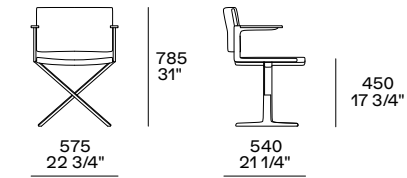
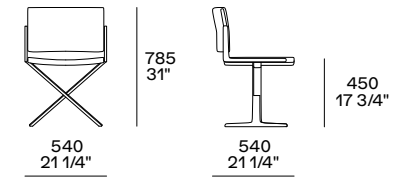

NEO CONCORDE TABLE



An icon of Plankfist design and a perfect expression of its timeless character, the Concorde table has been reinterpreted with softer, more fluid lines and updated details. Neo Concorde includes larger sizes and round shapes, introducing the new bevelled top and a glossy black elm finish for the structure.

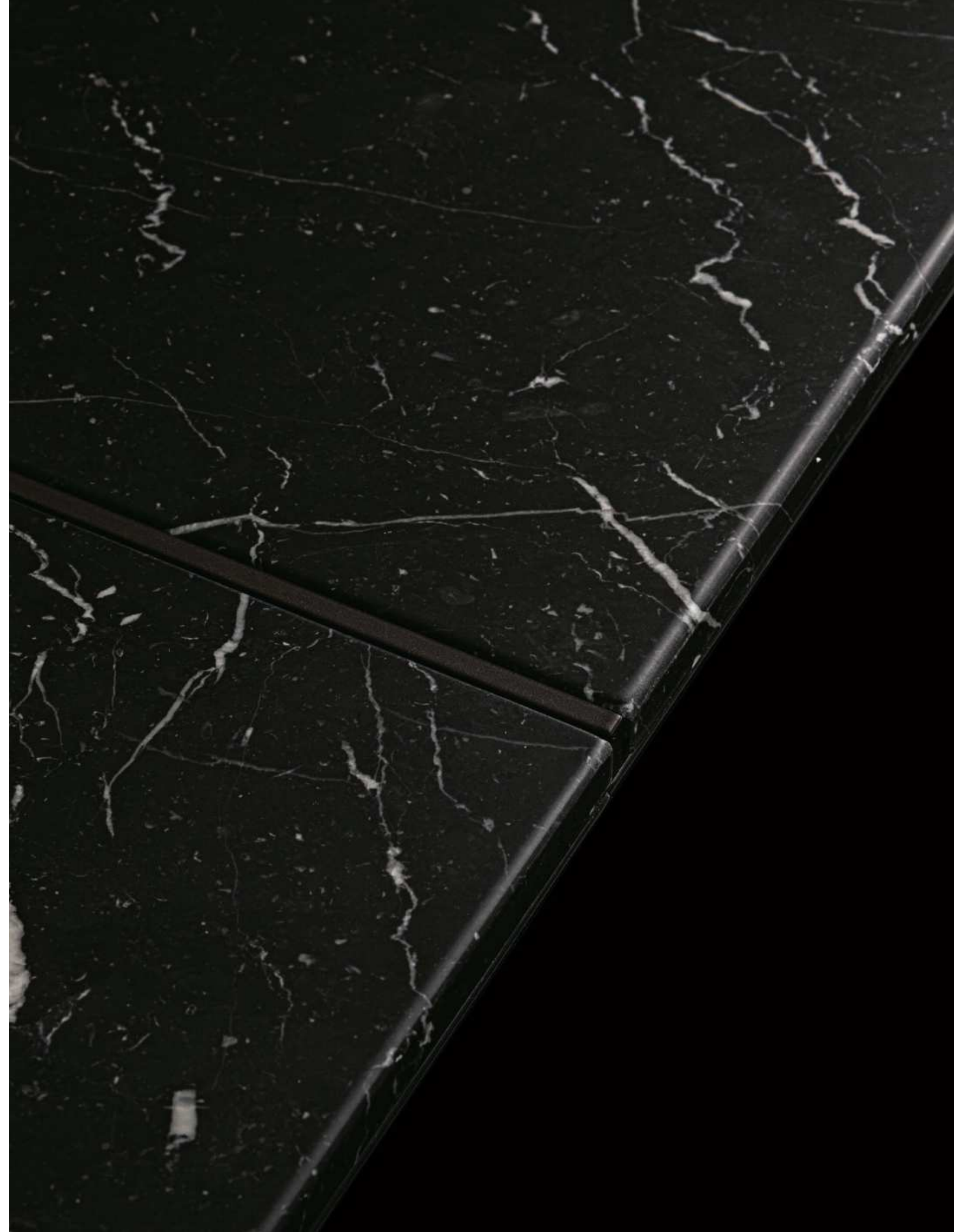





This and next page: Neo Concorde table with glossy black elm structure, top in mat calcatta oro marble with mat champagne metal inlay, central swivel tray in mat calcatta oro marble. Previous pages: Neo Concorde table with glossy black elm structure, top in mat nero marquina marble polyester finish with mat brown nickel inlay.



This page: close up of the Neo Concorde table with structure in glossy black elm.



This page: Neo Concorde table with glossy black elm structure and top in black elm.



This page: close up of the Neo Concorde table with structure in black elm and top in mat sahara noir marble polyester finish.



This page: Neo Concorde table with structure in black elm and top in mat sahara noir marble polyester finish.



NEO CONCORDE

Struttura in massello finitura rovere

Piano in rovere spessart, olmo nero o

1600, 1800, 2000 e 2500 e disponibile

in laccato lucido e opaco colori, rovere

lucido (escluso zecevo).

Structure in solid wood spessart oak finish, black elm and glossy black elm.

Top in spessart oak, black elm or mat and glossy marble (except zecevo). Top 70 3/4", 78 3/4" and 98 1/2" and top w 157 1/2" with mat brown nickel or mat champagne painted metal inlays. For the tables 63", 70 3/4", 78 3/4" and 98 1/2" the optional swivel tray is available, placed on top, in glossy and mat lacquer, spessart oak, black elm or mat and glossy marble (except zecevo).

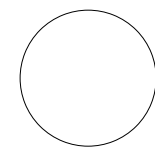
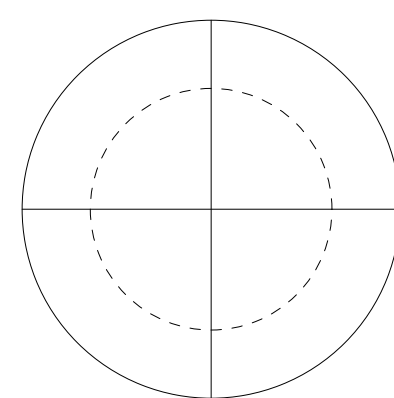
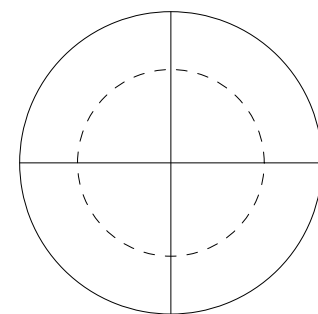
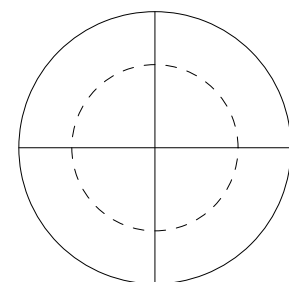
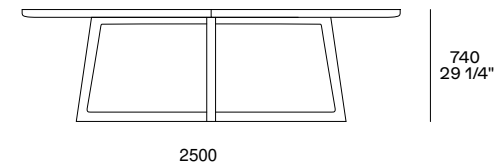
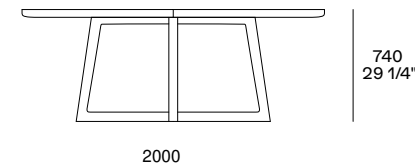
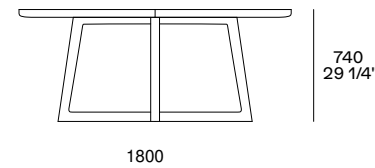
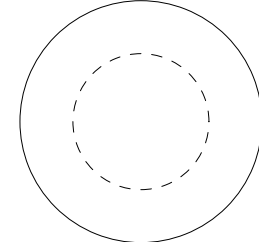
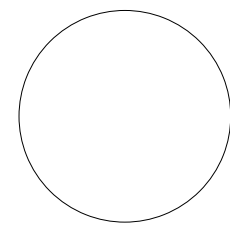
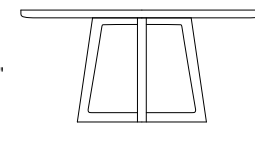
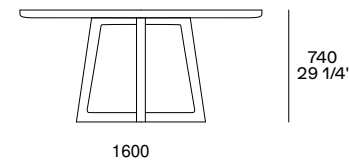
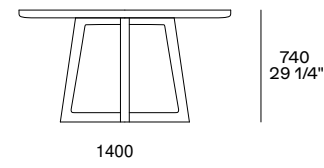

900-1100-1250-1600

vassoio girevole opzionale
optionl swivel tray

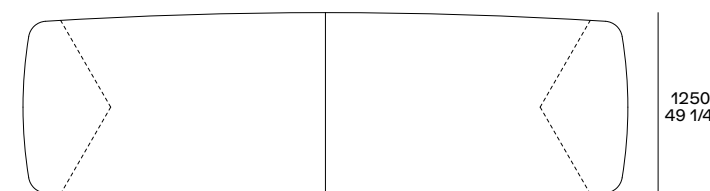
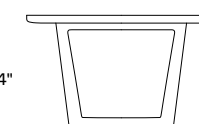
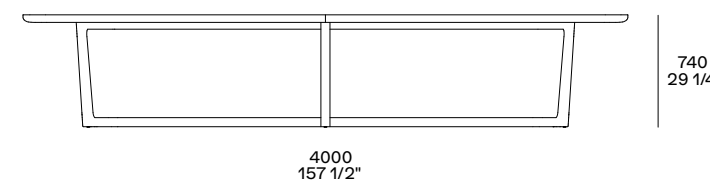
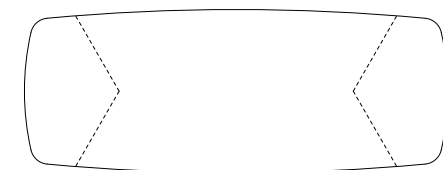
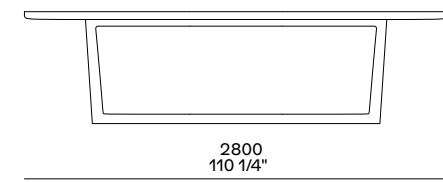
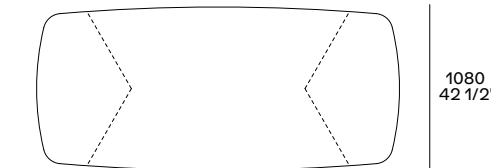
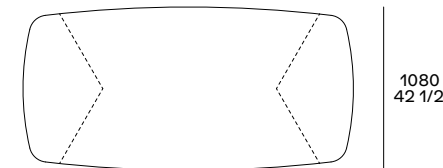
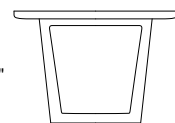
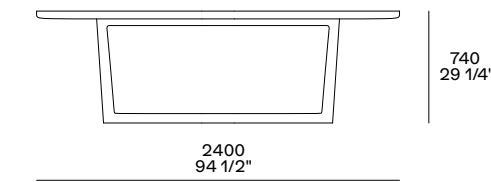
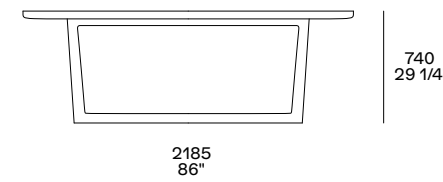

in legno
Close up of the top
in wood

VICTORIA CHAIR

The Victoria chair by Emmanuel Gallina is the ideal match for the Neo Concorde table. Defined by a wooden structure

ment, it results in a chair with a relaxed elegance that, in its taut curves and natural character, embodies a contemporary lifestyle.





This and next page: Victoria chair with removable cover in leather Suede 02 corda and glossy black elm structure. Previous pages: Victoria chair with removable cover in velvet Persia 1404 carbone and glossy black elm structure.





VICTORIA

Struttura in massello finitura rovere

Seduta e schienale in poliuretano flessibile stampato monoquota. Prerivestimento in

Structure in solid wood finish spessart oak, black elm and glossy black elm. Seat and backrest in single density moulded flexible polyurethane. Pre-cover in cotton canvas and polyester fiber. Removable cover in fabric or leather.

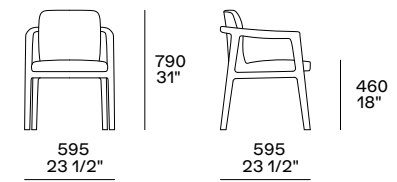

LANAI BED SYSTEM

yond the idea of a simple piece of furniture and envisioning the night area as a fully realised space for relaxation and personal time. Inspired by the contemporary bedroom, which increasingly becomes a space to be lived in throughout the day, Lanai expands the bed's functions with modular elements layered like a natural landscape. The padded volumes also draw inspiration from nature, perfectly balanced by straight, geometric lines.







This page, previous pages and next page: Lanai bed with structure in black elm, padded headboard with removable cover in fabric Metropolitan 115 pernice. Coordinated bed linen in cotton Provence 01 bianco with black profile and Provence 08 Polvere. Padded backrest and seats with removable cover in fabric Metropolitan 115 pernice.



LANAI

Design Yabu Pushelberg

Letto con testata in legno e derivati impiallacciato con imbottitura in poliuretano flessibile monoquota con prriverestimento in fibra di poliestere e rivestimento sfoderabile in tessuto o pelle.

Base letto in legno e derivati impiallacciato, cornice perimetrale in legno massello. Mensola opzionale e cassetto opzionale in

impiallacciato con imbottitura in poliuretano

prriverestimento in fibra di poliestere,

I 1800-2000 x p 2000

King size

I 1952 x p 2030

Tipologia di rete:

- rete fissa
- reti anatomiche

Bed with headboard in veneered wood and wood derivatives with padding in single density moulded flexible polyurethane with pre-cover in polyester fiber and removable cover in fabric or leather.

Bed base in veneered wood and wood derivatives, perimeter frame in solid wood. Optional shelf and optional drawer in veneered wood and wood derivatives.

Poufs with structure in veneered wood and wood derivatives with padding in moulded flexible polyurethane with differentiated densities, pre-cover in polyester fiber, cover in removable fabric or leather

Foreseen for mattresses:

w 70 3/4"-78 3/4" x d 78 3/4"

King size

w 76 3/4" x d 80"

Bedstead type:

- fixed bedstead
- anatomic bedsteads

Letto Bed

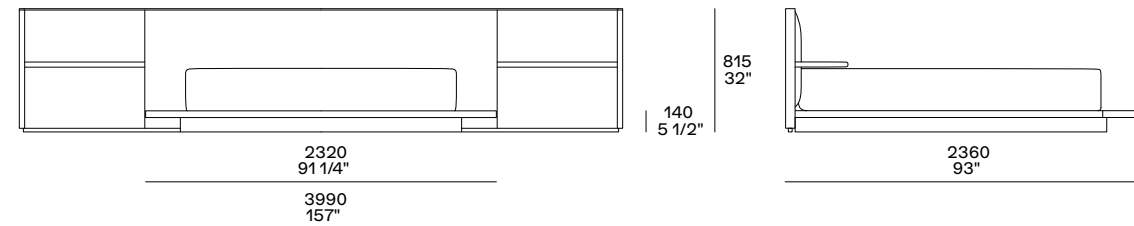

Bed with pouf behind the headboard

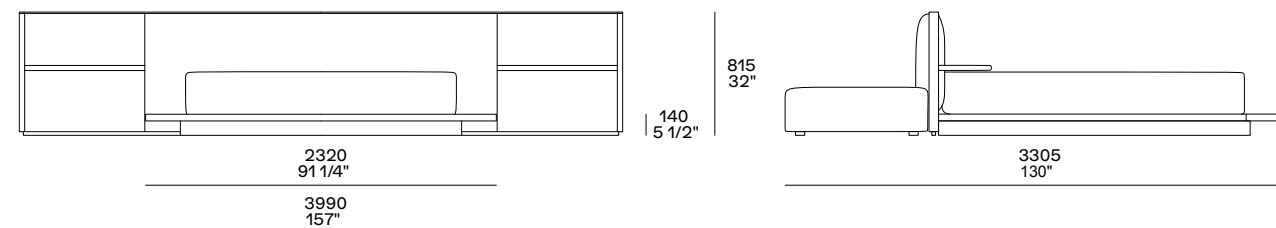

Bed with pouf and pouf behind the headboard

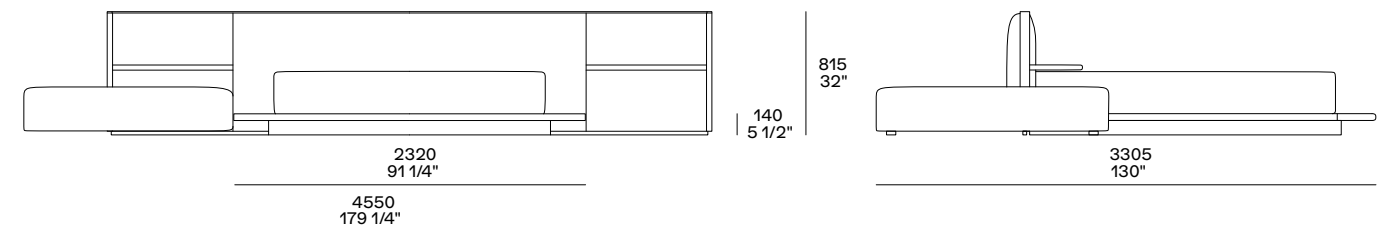

Bed with pouf

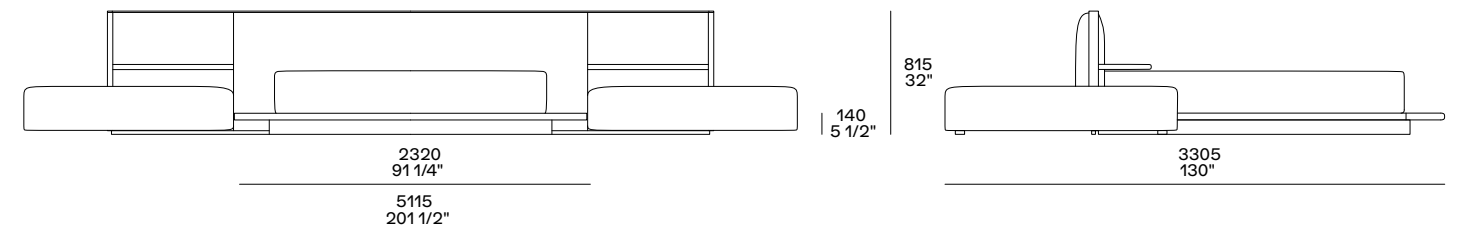

Pouf retroletto Pouf behind the headboard

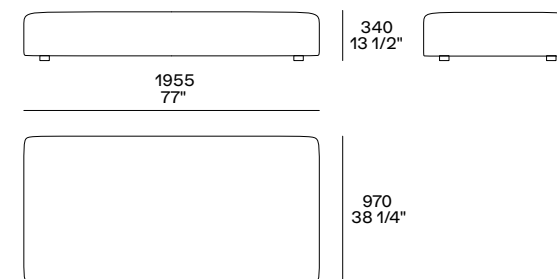

Pouf Pouf

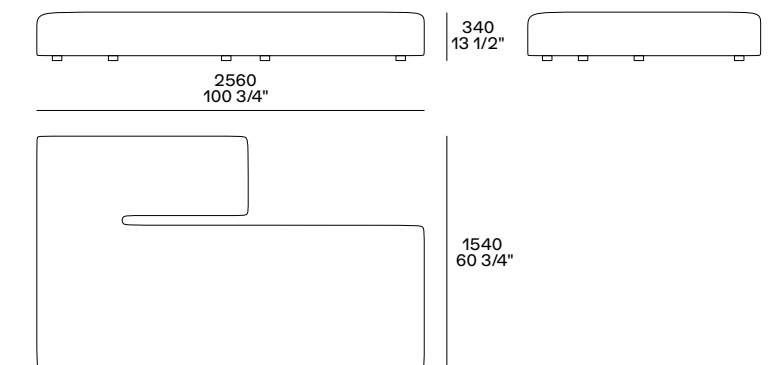

LANAI NIGHT COMPLEMENTS

The Lanai collection also includes chests of drawers and bedside tables, designed to meet everyday storage needs. Aesthetically, these pieces echo the bed in their layered composition and in the harmonious contrast between slim metal tops and more substantial wooden volumes, all characterised by curved edges.







LANAI

opaco colori.
Piano e inserti in pannello stratificato laccato
light sheer o dark sheer.

Structure in solid wood stained black elm or
mat lacquer colours.
Top and inserts in light sheer or dark sheer
lacquered laminated board

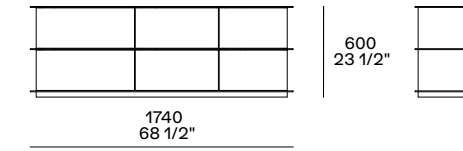
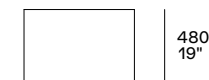
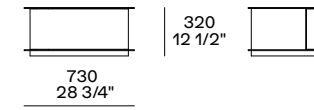

Left and previous pages: Lanai chest of drawers and bedside tables in black elm with top and inserts in dark sheer lacquer.

AQUALUNA ARMCHAIR

The Aqualuna armchair shares the same design language as the Lanai collection. Defined by soft, rounded forms, it conveys a sense of comfort, equally suited to the bedroom and to other areas of the home. Low and generous, and even more inviting in the version with a headrest, it offers enveloping support for deep relaxation.

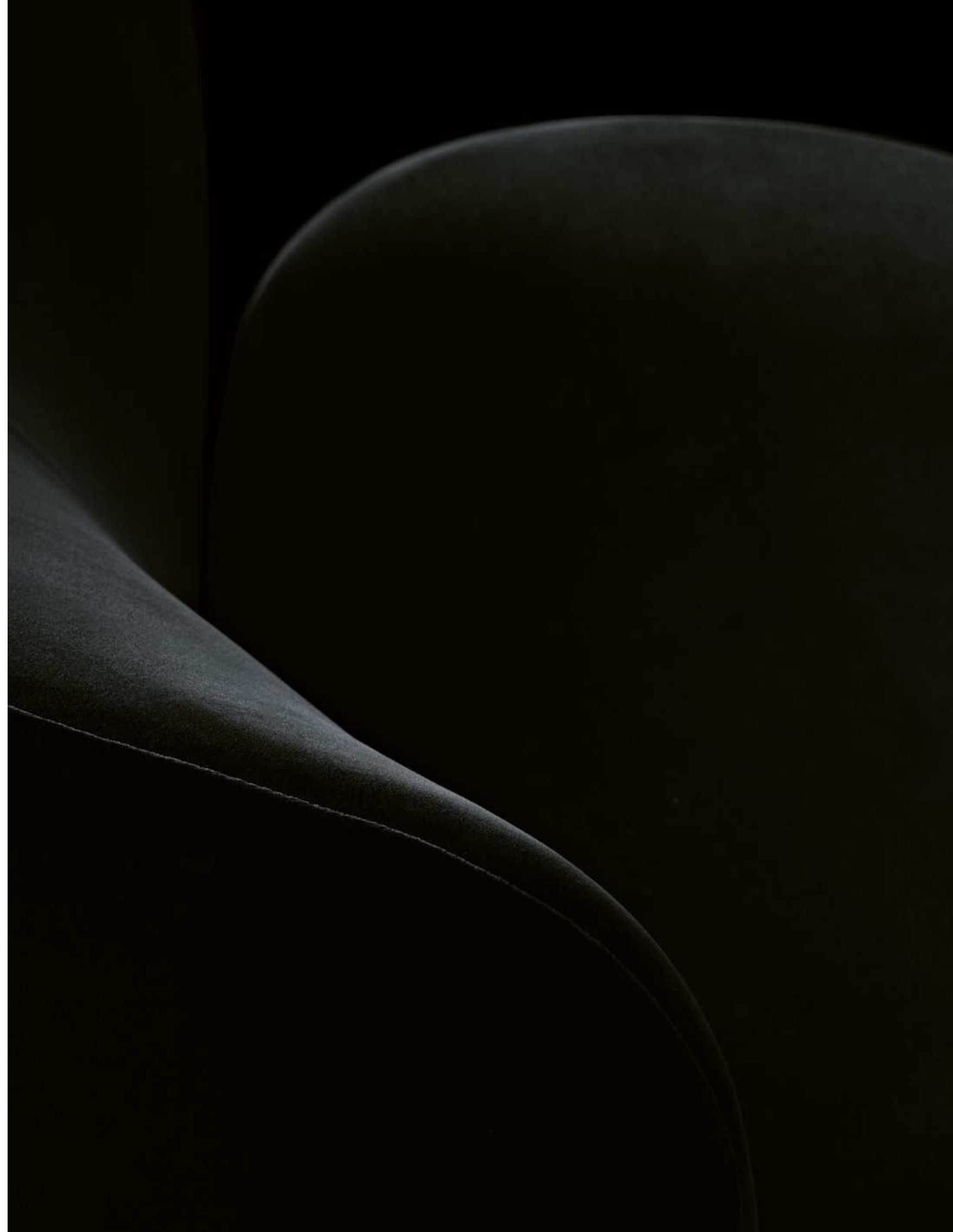



This page: close up of the Aqualuna armchair with removable cover in leather Nabuk 01 latte. Previous pages Aqualuna armchair with removable cover in velvet Persia 26 nero.



This page: Aqualuna armchair with removable cover in leather Nabuk 01 latte.



This and next page: Aqualuna Lounge armchair with removable cover
in fabric Siro 01 bianco.

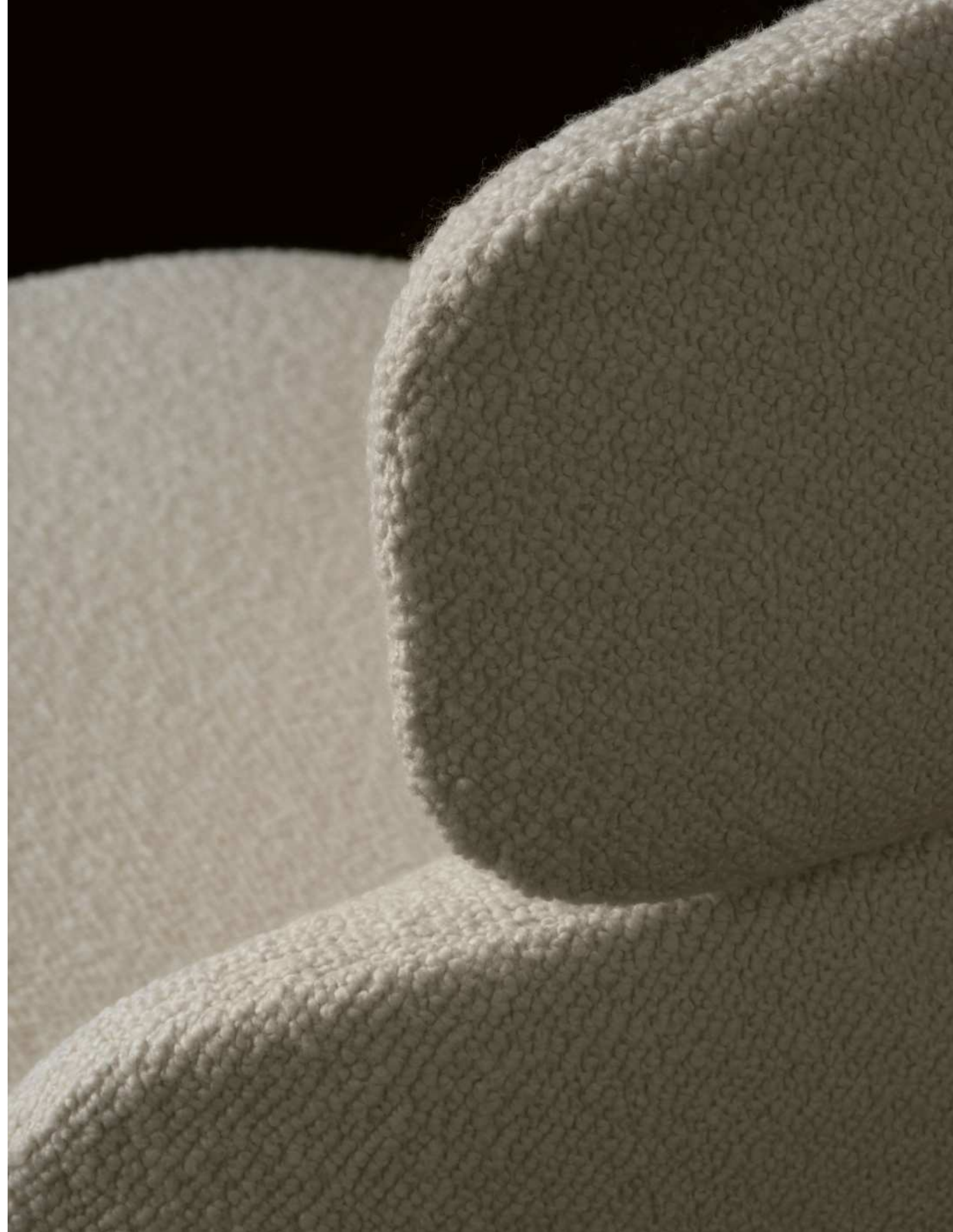



AQUALUNA

Removable cover in fabric or leather.

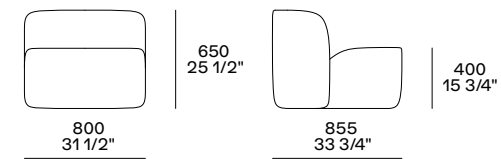

AQUALUNA LOUNGE

Design Yabu Pushelberg

Struttura in poliuretano flessibile stampato con inserto in poliuretano a quote differenziate, priverivestimento in tela cotone e fibra di poliestere.
 Base in pannello di fibra ad alta densità laccato opaco carbone o base girevole in metallo.
 Poggiatesta in poliuretano flessibile a quote differenziate.

Structure in moulded flexible polyurethane with insert in polyurethane with differentiated densities, pre-cover in cotton canvas and polyester fiber.
 Base in high-density fiberboard in mat lacquer carbone or swivel base in metal.
 Backrest in flexible polyurethane with differentiated densities.
 Removable cover in fabric or leather.

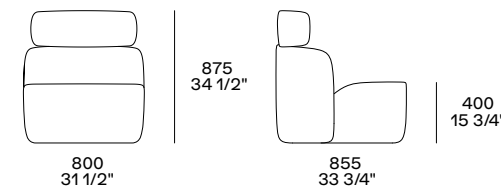

LANAI COFFEE TABLE

of the collection: the first through the interplay of slim and thicker elements, the second through the soft, rounded shaping of a wooden volume.





LANAI

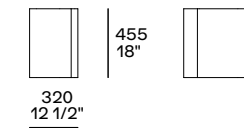
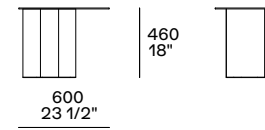

Left and previous page: Lanai coffee tables in black elm with top in dark sheer painted aluminium.

LANAI SIDEBOARD

Created to complete the night collection of the same name, the Lanai sideboard takes cues from the language of the living area, here reimagined in a new form designed for contemporary entertaining. Its soft, dynamic lines emerge from the layering of materials with contrasting thicknesses.







LANAI

opaco colori.
Piano e inserti in pannello stratificato laccato
light sheer o dark sheer.

Structure in solid wood stained black elm and
mat lacquered colours.
Top and inserts in light sheer or dark sheer
lacquered laminated board.

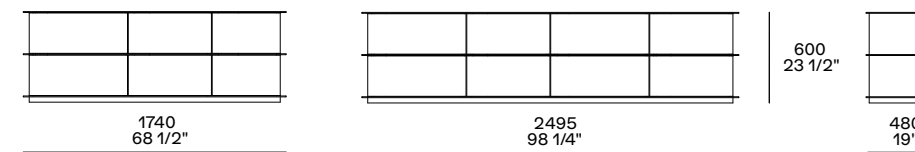

no e inserti in laccato dark sheer.

Left and prevoius pages: Lanai sideboard in black elm with dark sheer
lacquered top and inserts.

SUITE ISLAND

Suite island is a freestanding chest of drawers enriched by a soft seat, a versatile element for the contemporary wardrobe area, conceived as a space for personal wellbeing. Designed to complement wardrobes and walk-in closets, it draws on the refined finishes and sophisticated aesthetic of the Suite accessories.

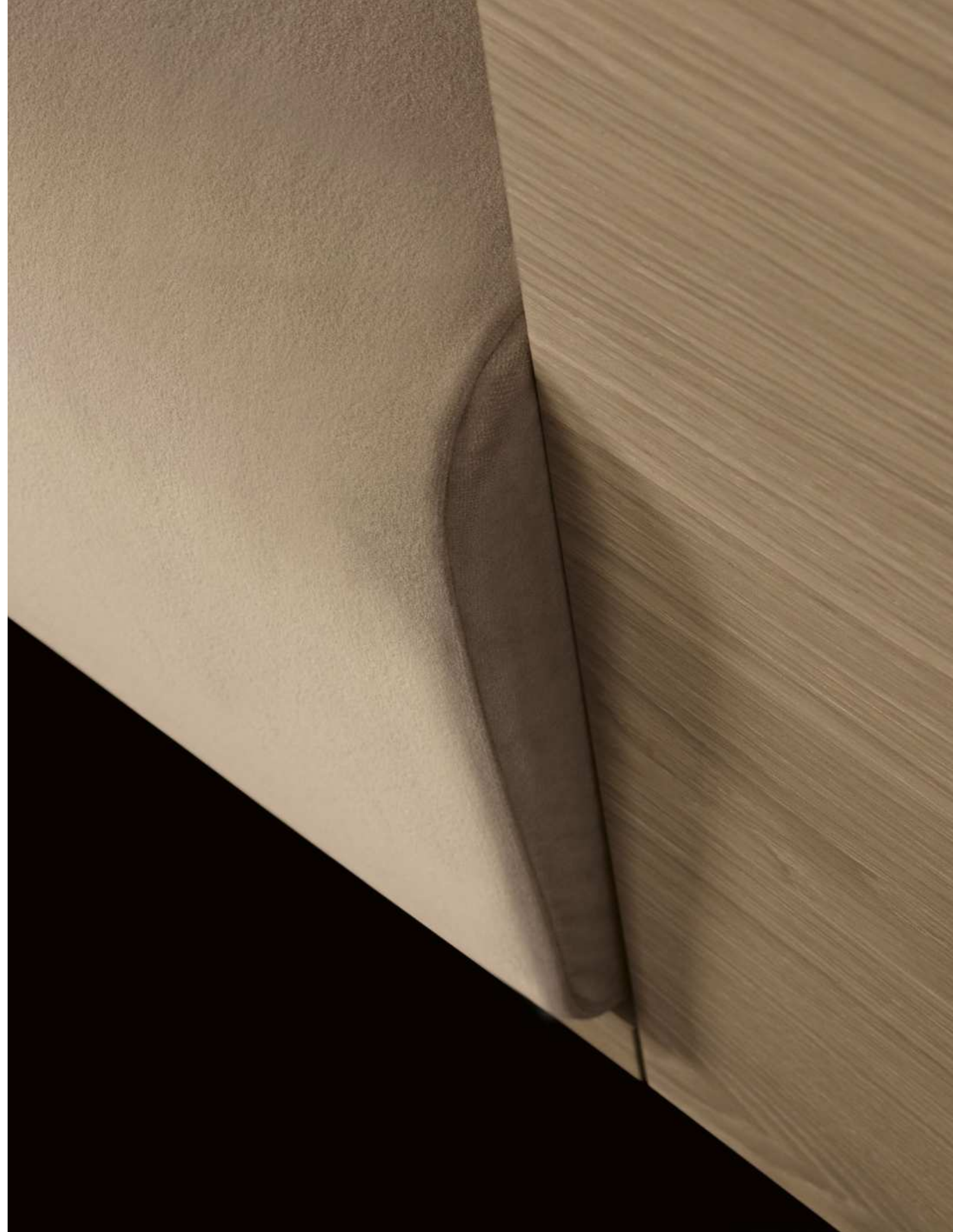



miele with lite oak frame. Drawers and trays in lite oak with Tilt handle in tecnocover grain 10 miele and mat champagne, bottom in tecnocover grain 10 miele; upper trays equipped with pleated fabric cover at the back to close the extraction space. Drawers in transparent reflecting glass with frame in lite oak melamine, push-pull opening, bottom in tecnocover grain 10 miele. Seat and backrest with removable cover in velvet Persia 03 perla.



SUITE

Struttura in essenza 5 finiture, piano superiore in vetro trasparente con telaio in essenza 5

Frontale cassetto in essenza o vetro

tecnocover grain solo per cassetto legno e vassoio.

Interno cassetto in nobilitato basalto, fondo opzionale in tecnocover grain.

Vassoio con frontale in essenza, interno e spondine in tecnocover grain.

Seduta in poliuretano monoquota, rivestimento sfoderabile in tessuto o pelle.

Parti metalliche in alluminio verniciato opaco

Structure in wood 5 finishes, top shelf in transparent glass with frame in wood 5 finishes and optional light.

Drawer front in wood or transparent glass with silk screen printing.

Tilt handle in mat painted metal and tecnocover grain only for wooden drawer and tray.

Drawer interior in melamine basalto, optional drawer bottom in tecnocover grain.

Tray with front in wood, interior and sides in tecnocover grain.

Seat in single-density polyurethane, removable cover in fabric or leather.

Metal parts in mat painted aluminium.

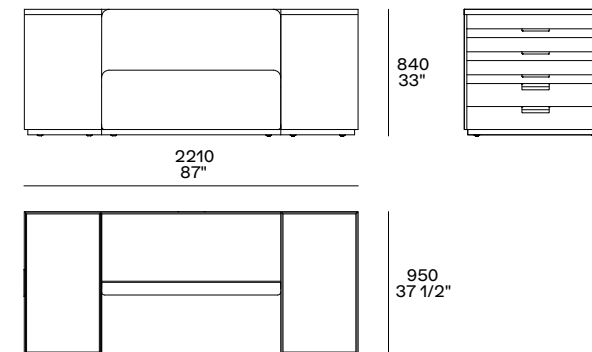

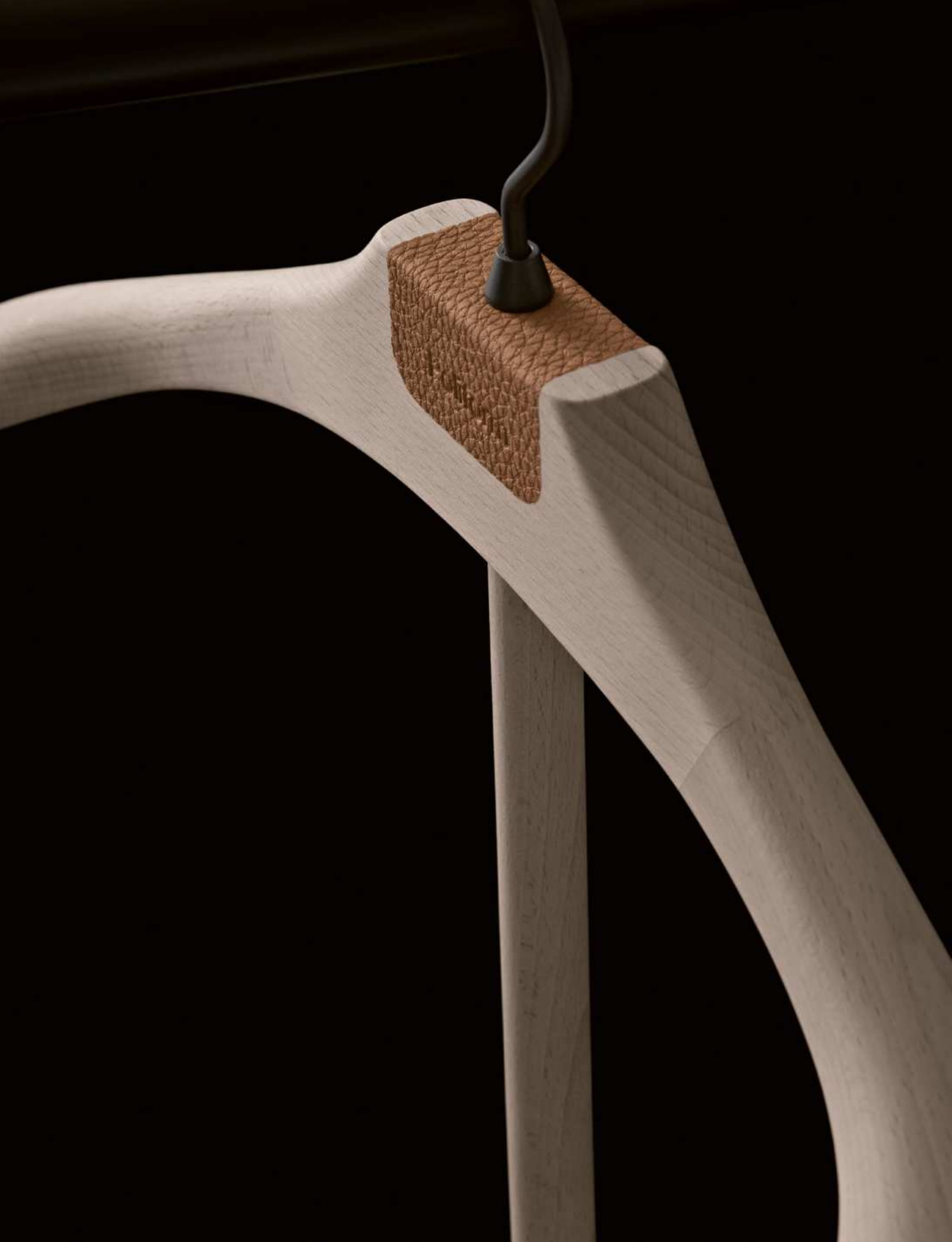

NIGHT SYSTEM ACCESSORIES

lection of Suite accessories, created to transform the functional elements of wardrobes and walk-in closets into refined and elegant details. Thanks to high-quality finishes designed to match the furnishings, these accessories move beyond pure functionality.





basalto, inserti in tecnocover grain 10 miele.

This and previous pages: hangers in ash, metal parts basalto, inlays in tecnocover grain 10 miele.

This and next page: basket in tecnocover grain 02 moro.





NIGHT SYSTEM ACCESSORIES

Design R&D Plankfist

Grucce in frassino, parti metalliche basalto,
inserti in tecnocover grain.
Cesta rivestita in tecnocover grain, maniglia

Hangers in ash, metal parts basalto, inlays in
tecnocover grain.
Basket covered in tecnocover grain, handle
in the same finish.

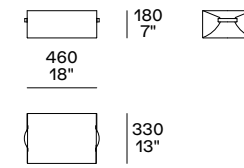

HUGO LAMP

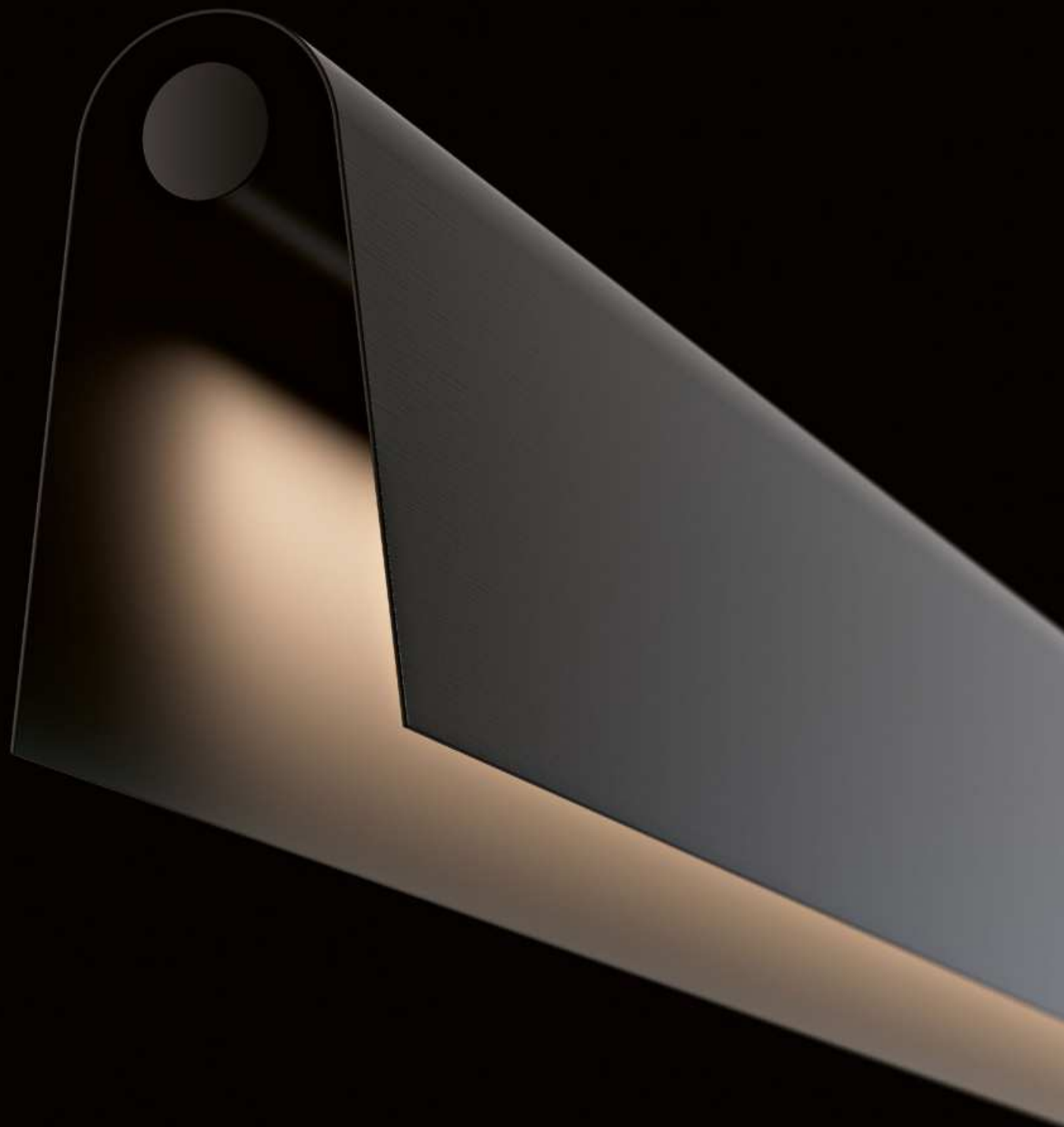

Hugo is a pendant lamp with a pared-back aesthetic, designed to cast a soft light over the dining table. Its minimalist lines evoke an idea of quiet luxury, distinguished by both discretion and expressiveness.



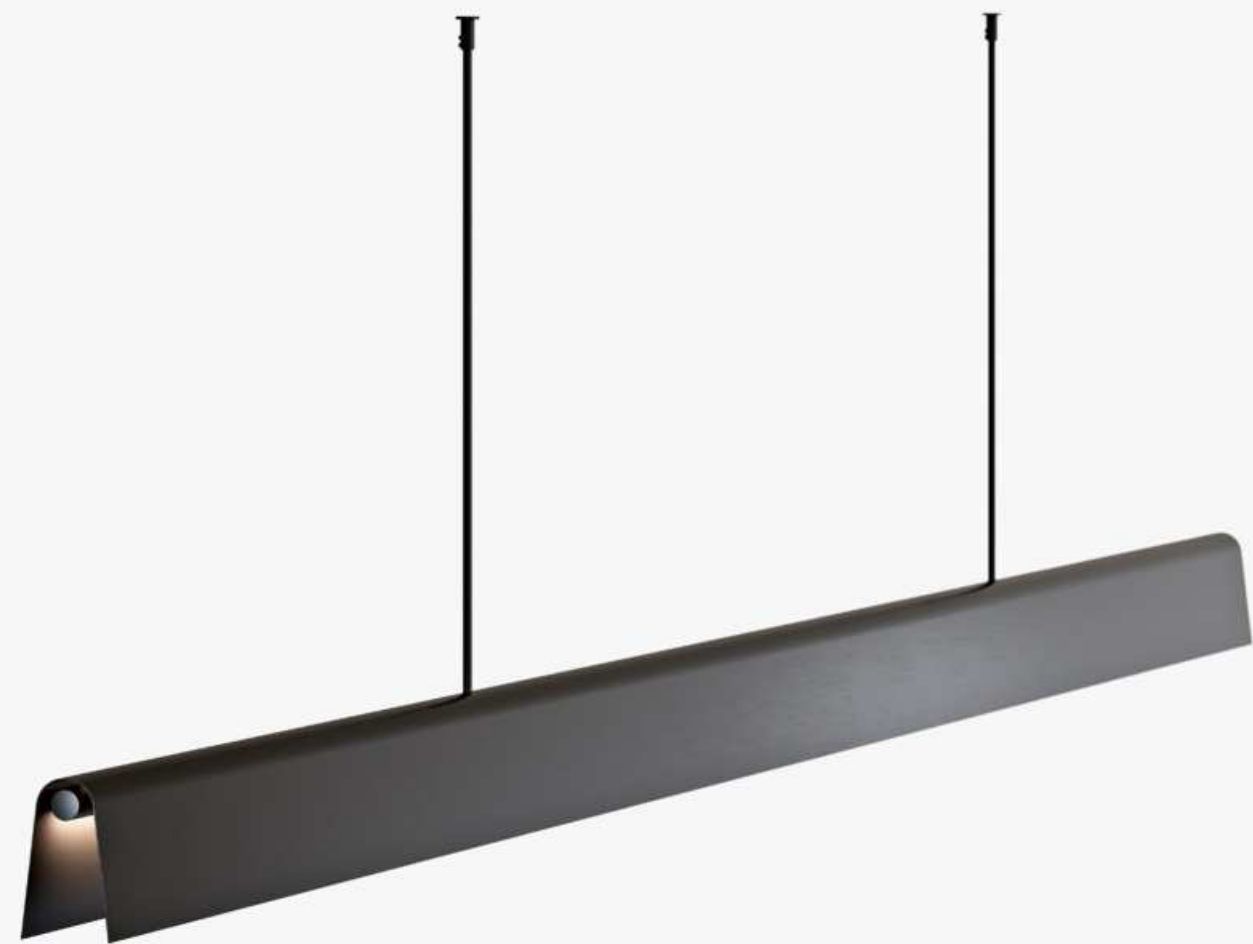

HUGO

calamina opaco

Structure in painted metal with mat calamine iron finish.
Dimmable led light 2700K.

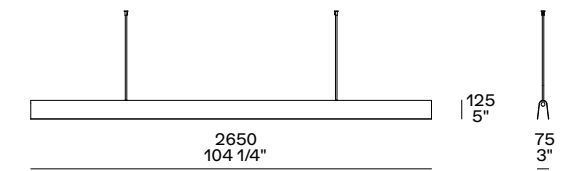
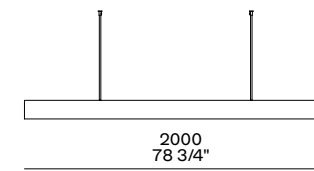

KLARA LAMP

Klara is a contemporary, minimalist reinterpretation of the traditional lamp, with subtle references to East Asian lanterns. The cylindrical light source is set within a refined frame that recalls the traditional gesture of carrying a lantern.





KLARA

Struttura in acciaio verniciato carbone opaco con inserto in cuoio nero. Corpo illuminante in vetro opalino satinato.

Structure in mat carbone painted steel with black hide insert. Light fixture with satin opal glass body.
Dimmable led light 2700K.

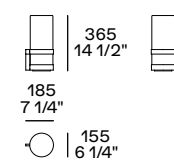



NEW INDOOR FABRICS

focus on soft, refined fabrics designed to offer rich tactile and visual appeal. The 2026 selection builds on previous collections, introducing two new chenilles with a rich, textured weave, alongside a brushed fabric characterised by irregular slubs and a distinctly modern, bold character. Completing the upholstery collection is a new aniline leather with a silky hand. A true expression of manufacturing expertise, its soft surface preserves the natural character of the material, giving this leather a uniquely refined quality.

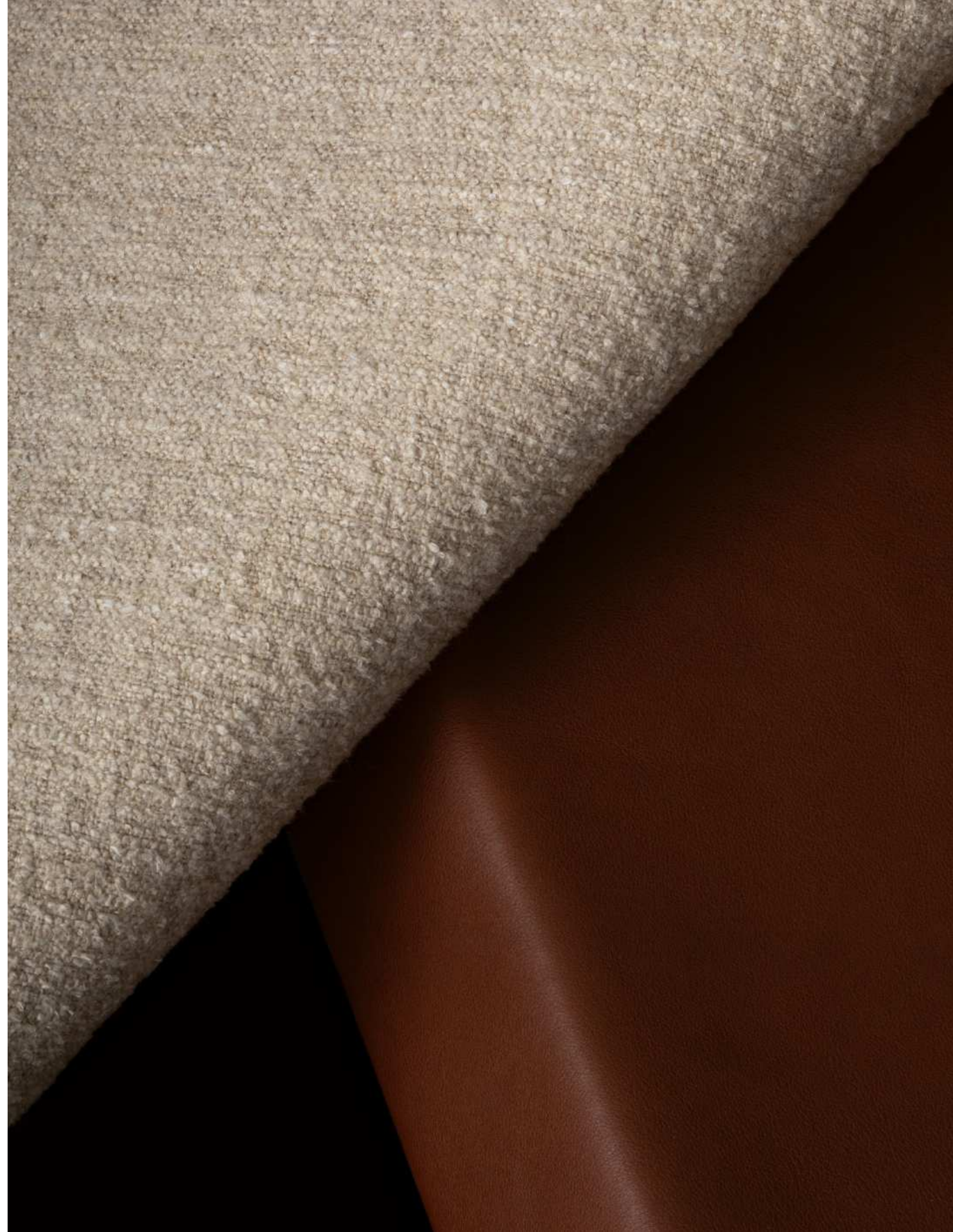

NUOVI TESSUTI INDOOR
NEW INDOOR FABRICS

Bolshoi
fabric cat. e



58 bianco



59 arena



11 polvere



23 tortora

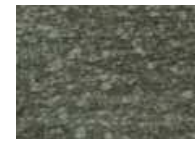

60 roccia



233 senape



234 oliva



232 bruciato



231 carbone



230 nero

Metropolitan
fabric cat. e



101 avorio

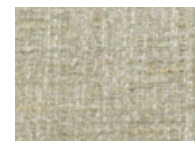

102 sabbia



115 pernice

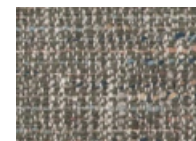

111 tortora



105 visone

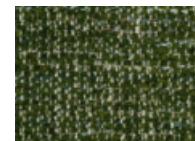

106 oliva

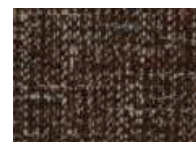

108 bruciato



109 ferro



205 carbone

Carnegie
fabric cat. g



01 bianco



02 lino



03 perla



04 tabacco



05 polvere

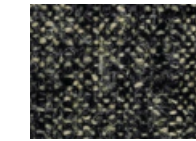

06 carbone

Pelle Ermitage
leather cat. w

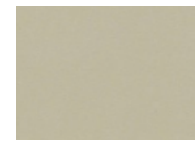

01 latte



02 lino



03 cognac



04 tabacco



05 stone



06 moka

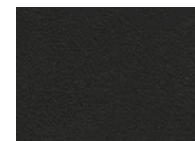

07 carbone

INDOOR PROPOSALS

COMPOSITION 01	258
COMPOSITION 02	260
COMPOSITION 03	262
COMPOSITION 04	264
COMPOSITION 05	266
COMPOSITION 06	268
COMPOSITION 07	270
COMPOSITION 08	272
COMPOSITION 09	274
COMPOSITION 10	276



COMPOSITION 01

e acciaio lucido. Lampade Arthur in acciaio inox satinato e luce a led dimmerabile. Tappeto Trace ruggine.

Savoy sofa in removable fabric Carson 02 corda, sofa back structure in glossy lacquer carbone, mat brown nickel feet. Alfred armchair in removable leather Ermitage 07 carbone. Joan coffee tables in black elm and glossy steel. Arthur lamps in satin-finish stainless steel and dimmable led light. Carpet Trace ruggine.



COMPOSITION 02

rabile Nabuk 10 oliva, retrodivano in olmo nero, piedini in brown nickel

Savoy con struttura in brown nickel satinato, piano in vetrofusione bosco. Lampada Arthur in acciaio inox satinato e luce a led dimmerabile. Tappeto Plain tortora.

Savoy sofa in removable fabric Konik 06 grafite, sofa back structure in black elm, mat brown nickel feet. Savoy armchair in removable leather Nabuk 10 oliva, sofa back structure in black elm, mat brown nickel feet. Joan coffee tables in black elm and glossy lacquer tundra. Savoy coffee table with structure in satin-finish brown nickel, top in fused glass bosco. Arthur lamp in satin-finish stainless steel, dimmable led light. Carpet Plain tortora.



COMPOSITION 03

derabile Ermitage 03 cognac, piedini in brown nickel opaco. Tavolini

Shindo natural.

Savoy sofa in removable fabric Bolshoi 58 bianco, sofa back structure in black elm, mat brown nickel feet. Savoy armchair in removable leather Ermitage 03 cognac, mat brown nickel feet. Joan coffee tables in glossy lacquer moka. Savoy coffee table with structure in satin-finish brown nickel, top in mat calacatta oro marble. Arthur lamp in calamine iron-finish painted metal and dimmable led light. Carpet Shindo natural.



COMPOSITION 04

Savoy sofa in removable fabric Persia 2002 bruciato, sofa back structure in black elm, mat brown nickel feet. Aqualuna Lounge armchair in leather Nabuk 01 latte. Joan coffee tables in black elm and glossy lacquer moka. Savoy coffee tables with structure in satin-finish brown nickel, top in fused glass bronzato. Arthur lamp in calamine iron-finish painted metal and dimmable led light. Carpet Trace natural.



COMPOSITION 05

levigato rosso lepanto. Lampada Arthur in acciaio inox satinato e luce

Savoy sofa in removable leather Ermitage 01 latte, sofa back structure in black elm, mat brown nickel feet. Alfred armchair in removable fabric Shedir 02 burro. Adrien coffee tables in glossy lacquer mosto. Savoy coffee tables with structure in satin-finish brown nickel, top in mat marble rosso lepanto. Arthur lamp in satin-finish stainless steel and dimmable led light. Carpet Plain natural.



COMPOSITION 06

ckel satinato, piano in vetrofusione bronzo. Lampada Helga in metallo
white.

Savoy sofa in removable fabric Arcadia 03 canapa, mat brown nickel
feet. Savoy armchair in removable leather Nabuk 01 latte. Adrien cof-
fee tables in black elm. Savoy coffee table with structure in satin-fin-
ish brown nickel, top in fused glass bronzo. Helga lamp in calamine
iron-finish painted metal and dimmable led light. Carpet Trace white.



COMPOSITION 07

Savoy sofa in removable fabric Carnegie 01 bianco, sofa back structure in glossy lacquer carbone, mat brown nickel feet. Aqualuna armchair in removable velvet Persia 26 nero. Adrien coffee tables in black elm and with top in mat calacatta oro marble, structure in black elm. Helga lamp in calamine iron-finish painted metal and dimmable led light. Carpet Frame natural.



COMPOSITION 08

Lampada Helga in acciaio inox satinato e luce a led dimmerabile.
Tappeto Trace ecru.

Savoy sofa in removable fabric Bolshoi 11 polvere, sofa back structure in black elm, mat brown nickel feet. Alfred armchair in leather Natural 04 fango. Adrien coffee tables in black elm and with top in mat nero marquina marble polyester finish, structure in black elm. Helga lamp in satin-finish stainless steel and dimmable led light. Carpet Trace ecru.



COMPOSITION 09

retrodivano in laccato lucido carbone, piedini in brown nickel opaco.

Shindo natural.

Savoy sofa in removable fabric Carnegie 02 lino, mat brown nickel feet. Savoy armchair in removable leather Ermitage 04 tabacco, sofa back structure in glossy lacquer carbone, mat brown nickel feet. Joan coffee tables in black elm and glossy steel. Helga lamp in calamine iron-finish painted metal and dimmable led light. Carpet Shindo natural.



COMPOSITION 10

cato lucido carbone, piedini in brown nickel opaco. Poltrona Aqualuna

tere. Lampada Arthur in acciaio inox satinato e luce a led dimmerabile.
Tappeto Trace natural.

Savoy sofa in removable leather Nabuk 04 moka, sofa back structure in glossy lacquer carbone, mat brown nickel feet. Aqualuna Lounge armchair in removable fabric Siro 01 bianco. Joan coffee tables in black elm and glossy lacquer moka. Savoy coffee table with structure in satin-finish brown nickel, top in mat nero marquina marble polyester finish. Arthur lamp in satin-finish stainless steel, dimmable led light. Carpet Trace natural.

FINITURE INDOOR
INDOOR FINISHINGS

Mat and glossy lacquer



01 bianco 35 canapa 26 corda 13 nocciola 10 liquirizia 12 torba



48 visone 49 moka 82 glacier white 60 ghiaccio 11 mastice 64 arena



89 roccia 91 carbone 14 oceano 15 ottanio 16 tundra 19 ginger



21 sella 20 borgogna 22 mosto

Mat lacquer



77 champagne 24 ottone 27 basalto 02 ardesia 23 bronzo

**Laccato antigraffio
Scratchproof lacquer**

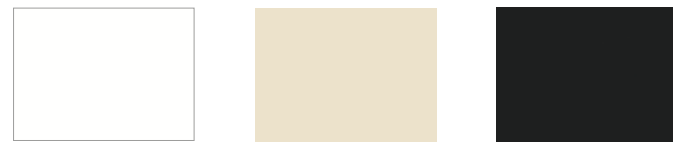

01 bianco 35 canapa 91 carbone

**Essenza
Wood**



rovere lite lite oak rovere gold gold oak rovere spessart spessart oak noce c walnut c black elm glossy black elm



massello cedro solid cedar massello noce solid walnut massello noce canaletto solid walnut canaletto

**Essenza Print
Wood Print**



rovere lite print lite oak print rovere gold print gold oak print rovere spessart print spessart oak print noce c print walnut c print black elm print

**Essenza Juta *
Wood Juta**



rovere lite juta lite oak juta rovere spessart juta spessart oak juta noce c juta walnut c juta black elm juta

armadio Senzafine
only for Juta door
Senzafine wardrobe

**Laccato metallico
Metal lacquer**



basalto ottone bronzo

**Acciaio
Steel**



acciaio lucido glossy steel

● news

FINITURE INDOOR
INDOOR FINISHINGS

**Cuoio
Hide**

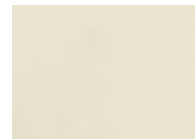

09 burro



29 tortora

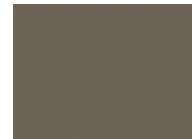

08 fango

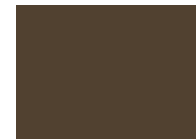

19 caffè



26 invecchiato



07 castagna

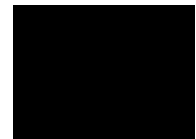

02 nero

**Tecnocover Grain
Tecnocover Grain**



05 latte



01 elefante

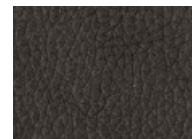

02 moro



06 nocciola



07 roccia

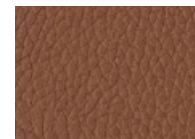

08 cognac

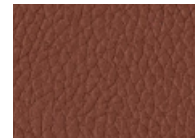

09 terracotta



10 miele

**Tessuto
Fabric**



lino chiaro



lino ecru



lino bruciato



lino scuro



mesh ecru



mesh peltro



mesh moka



mesh bronzo



mesh ruggine

**Inalco MDi
Inalco MDi**



rigato chiaro

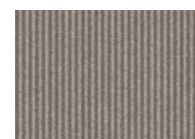

rigato scuro

**Corda intrecciata
Braided rope**



cenere

● news

TECHNICAL DATA

Mat marble



bianco carrara



calacatta oro



oyster white

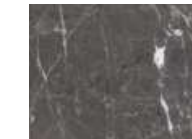

grigio stardust



verde lepanto



rosso lepanto



zecevo



travertino classico
poro chiuso - closed pore



travertino titanium
poro chiuso - closed pore



sahara noir
finitura poliester
polyester finish



nero marquina
finitura poliester
polyester finish

**Marmo lucido
Glossy marble**



bianco carrara



calacatta oro



oyster white



grigio stardust



verde lepanto

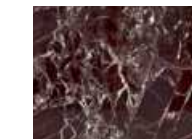

rosso lepanto



sahara noir
finitura poliester
polyester finish



nero marquina
finitura poliester
polyester finish



noir saint laurent

**Onice
Onyx**



ambra
amber

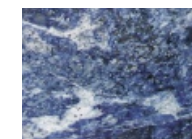

lapislazzulo blu
blue lapis lazuli

**Semiprezioso
Semiprecious stone**

**Pietra spatolata
Spatula-finish stone**



ebano
ebony

NEWS 2026

283

FINITURE INDOOR
INDOOR FINISHINGS

Tessuti
Fabrics



chios cat. b
13 colori - colours

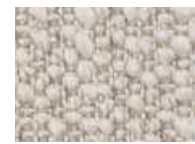

eraclea cat. b
12 colori - colours

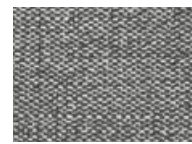

lima cat. c
11 colori - colours



antea cat. d
13 colori - colours



irati cat. d
11 colori - colours



kiara cat. d
13 colori - colours

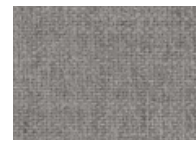

kushiro cat. d
13 colori - colours



micene cat. d
9 colori - colours

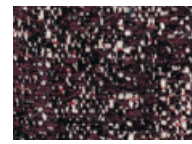

olimpia cat. d
14 colori - colours



rabat cat. d
10 colori - colours

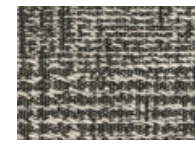

sendai cat. d
5 colori - colours



sparta cat. d
12 colori - colours



yukon cat. d
20 colori - colours



9 colori - colours



12 colori - colours



12 colori - colours



13 colori - colours



10 colori - colours



10 colori - colours



10 colori - colours

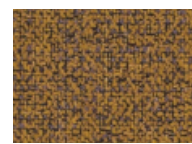

12 colori - colours

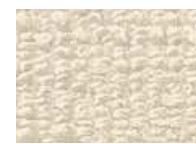

11 colori - colours



8 colori - colours



9 colori - colours

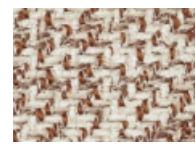

9 colori - colours



7 colori - colours



11 colori - colours



10 colori - colours



10 colori - colours



16 colori - colours



14 colori - colours



6 colori - colours

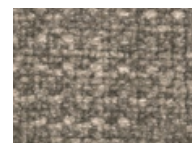

9 colori - colours

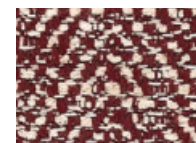

12 colori - colours

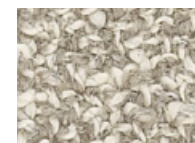

brest cat. g
10 colori - colours



carnegie cat. g
6 colori - colours



dundee cat. g
6 colori - colours



glasgow cat. g
6 colori - colours



hamal cat. g
4 colori - colours

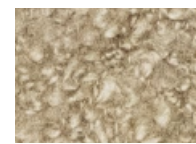

lero cat. g
2 colori - colours



nancy cat. g
6 colori - colours



norwich cat. g
8 colori - colours



sheffield cat. g
9 colori - colours



siro cat. g
4 colori - colours



tebe cat. g
11 colori - colours

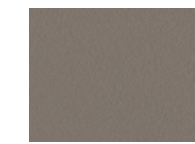

ecotech cat. m
7 colori - colours

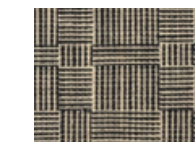

janaki cat. m
6 colori - colours

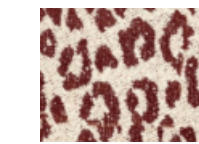

mintaka cat. m
3 colori - colours



yushan cat. m
6 colori - colours



gibson cat. z
6 colori - colours

Pelle
Leather



spring cat. p
13 colori - colours



colors cat. s
25 colori - colours

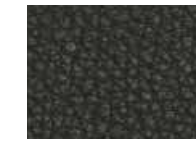

silk cat. s
13 colori - colours



silk intrecciata cat. s
woven leather silk
13 colori - colours

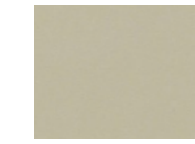

ermitage cat. w
7 colori - colours



deep cat. x
10 colori - colours



special cat. x
21 colori - colours



suede cat. x
7 colori - colours



nabuk cat. y
10 colori - colours



nabuk intrecciata cat. y
woven leather nabuk
10 colori - colours



natural cat. y
10 colori - colours



soft cat. y
14 colori - colours

Pelliccia Cashmere
Cashmere fur

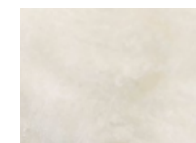

bianco

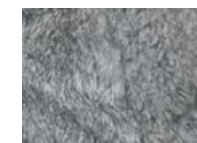

grigio



nero

Pelle Hairy
Hairy leather



bianco/nero



cappuccino



nero

Tecnocover Pixel
Pixel tecocover

Paglia sintetica
Synthetic straw



FINITURE INDOOR
INDOOR FINISHINGS

Bordura gros-grain - filati
Grosgrain border - yarns



burro perla nuvola cenere sahara terra

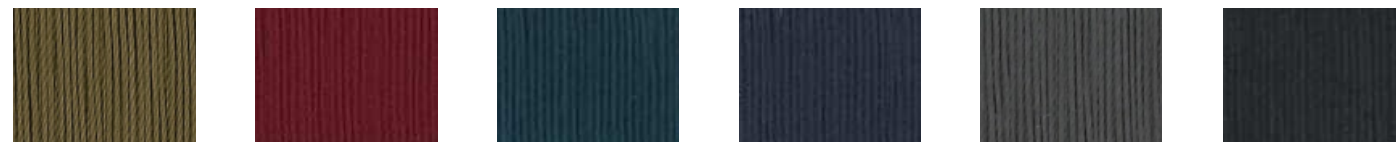

oliva amaranto tempesta navy acciaio nero

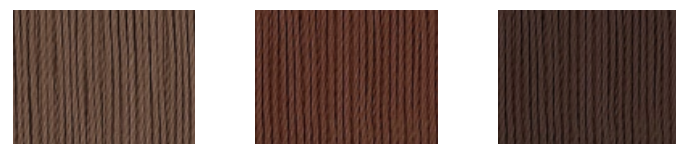

cioccolato caramel moro

Provence coordinati letto
Bed linen Provence



01 bianco 02 panna 08 polvere 04 tortora 06 roccia 07 grafite



03 ghiaccio

Coperta Linus
Linus blanket

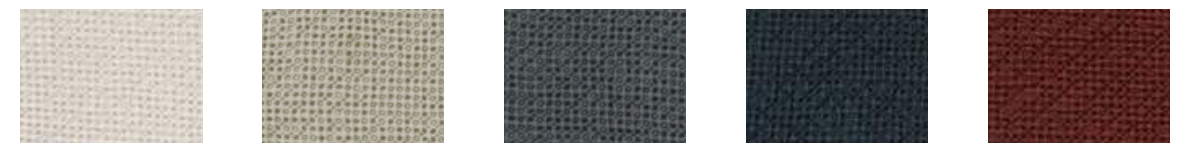

latte corda grafite notte granata

Lampade
Lamps



acciaio inox satinato satin stainless steel ferro calamina calamine iron ● lino bianco white linen carbone opaco mat carbone ● vetro opalino satinato ● satin opal glass ●

FINITURE INDOOR
INDOOR FINISHINGS

**Vetro
Glass**



1000 trasparente
transparent



2000 trasparente
extrachiaro-transparent
extralight



3051 bronzato
bronzed



3050 fume

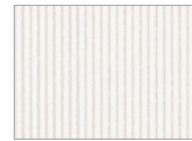

Inalco MVi
Inalco MVi

2901 rain bianco



2905 rain ecru

**Vetro riflettente
Reflecting glass**



5000 trasparente
transparent



5010 blu



5051 bronzato
bronzed



5059 fume

**Vetro acidato
Etched glass**



5380 acciaio

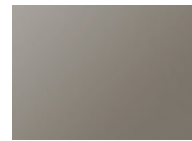

5323 bronzo



5325 titanio

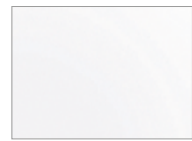

**Specchio
Mirror**

4000 bianco
white



4051 bronzato
bronzed



4050 fume

Mat and glossy glass



bianco
extrachiaro - extralight
2301 satinato - mat
2201 lucido - glossy

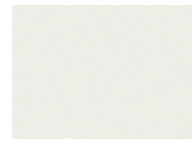

ghiaccio
2373 satinato - mat
2273 lucido - glossy

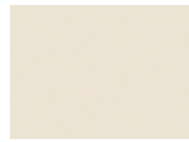

canapa
1335 satinato - mat
1235 lucido - glossy



arena
1364 satinato - mat
1264 lucido - glossy



nero
1303 satinato - mat
1203 lucido - glossy

**Vetro stratificato
Stratified glass**

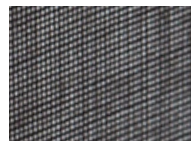

2C01 lino carbone
linen carbone

**Vetrofusione
Fused glass**



bronzo
bronze



fume
fume



bosco

**Vetrofusione rigato
Fused glass rigato**



bronzo
bronze



fume

**Nobilitato
Melamine**



olmo
elm



noce blond
blond walnut

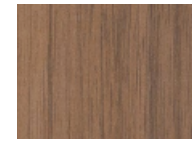

noce brown
brown walnut



rovere spessart
spessart oak

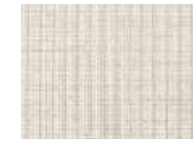

canvas beige



canvas tortora



basalto



club 01 bianco



silk canapa



silk grey



silk bronzo

Melamine drawers structure



basalto

**Parti metalliche
Metal parts**



brown nickel opaco
mat brown nickel



brown nickel lucido
glossy brown nickel



brown nickel satinato
brushed brown nickel



champagne opaco
mat champagne



champagne satinato
brushed champagne



ardesia opaco
mat ardesia



romo satinato
brushed chrome



romo nero
black chrome



romo nero satinato
brushed black chrome

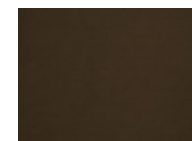

bronzato
bronzed



brunito opaco
mat brunito

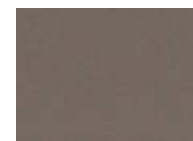

basalto opaco
mat basalto



spatolato ferro
spatula-finish ferro



spatolato bronzo
spatula-finish bronzo



oro lucido
glossy gold



alluminio brill
aluminium brill

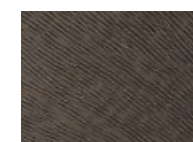

bronzo anticato
antique bronze

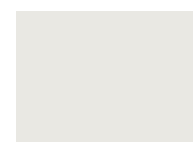

avorio opaco
mat avorio



light sheer opaco
mat light sheer



light sheer lucido
glossy light sheer



dark sheer opaco
mat dark sheer



dark sheer lucido
glossy dark sheer

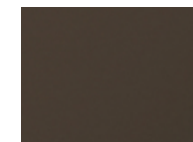

dark sheer raw



oxid opaco
mat oxid

INDOOR KITCHEN COLLECTION



HARP KITCHEN

The Harp kitchen stems from a search for harmony between the defined geometries of existing models and the softer curves that define Plankfist's new living spaces. The sinuous lines of worktops and doors are counterbalanced by a graphic detail: in the base units, this line marks the break between the top and the recessed handle, while in the tall units it creates a dynamic rhythm that defines the openings. Materials are carefully selected, including woods with craft-inspired finishes, marble worktops and brushed steel details.











HARP

Design R&D Plankfist

Isola p 1280

Struttura: nobilitato grigio lavagna.

verticale.

Gola orizzontale: rovere lite.

Fianchi di finitura arrotondati: rovere lite, spessore 220 mm.

spigoli arrotondati, spessore 60 mm, profilo String acciaio scotch brite, spessore 8 mm.
Zoccolo: rovere lite.

sponde in anodizzato moka, finitura interna in olmo nero.

Snack

Isola p 1280

Struttura: nobilitato grigio lavagna.

Gola orizzontale: acciaio scotch brite.

Fianchi di finitura: acciaio scotch brite, spessore 100 mm.

Top: acciaio scotch brite, spessore 60 mm, profilo String acciaio scotch brite, spessore 8 mm.

Zoccolo: acciaio scotch brite.

brown.

Basi p 840

Strutture: nobilitato grigio lavagna.

verticale.

Gola orizzontale: rovere lite.

Gola verticale terminale: rovere lite, spessore 25 mm.

Top: marmo travertino classico, levigato, spessore 60 mm, profilo String acciaio scotch brite, spessore 8 mm.

brite, spessore 20 mm.

brite spessore 8 mm.

Zoccolo: rovere lite.

sponde in anodizzato moka, finitura interna in olmo nero.

Pensili p 510

Strutture: nobilitato grigio lavagna.

verticale.

Gola orizzontale: rovere lite.

Gola verticale terminale: rovere lite, spessore 25 mm.

nero, spessore 30 mm, illuminazione orizzontale multiled integrata Dual Color.
Pannello sottopensile: acciaio scotch brite, spessore 8 mm, illuminazione orizzontale multiled integrata Dual Color.

Boiserie Harp:

verticale, profilo String acciaio scotch brite.

Colonne Full High p 740

Strutture: nobilitato grigio lavagna.

e verticale.

Gola verticale: rovere lite, profilo String acciaio scotch brite.

Zoccolo: nobilitato grigio lavagna h 100 mm.

Pivot Kitchen:

80 mm.

moka.

Colonna Ghost p 740

verticale, profilo String acciaio scotch brite.

Zoccolo: laccato goffrato moka, h 100 mm.

sponde in anodizzato moka, finitura interna in olmo nero.

Island d 50 1/2"

Structural elements: lavagna grey melamine.

Doors: lite oak, horizontal and vertical vein.

Horizontal channel: lite oak.

Rounded finishing sides: lite oak, thickness 8 3/4".

Top: marble classic Travertine mat, rounded corners, thickness 2 1/4", String profile steel scotch brite, thickness 1/4".

Plinth: lite oak.

Dress System: drawers and pull-out with anodized moka sides, inner finish in black elm.

Equipment for drawers: black elm.

Snack

Harp: marble classic Travertine mat

Island d 50 1/2"

Structural elements: lavagna grey melamine.

Doors: steel scotch brite.

Horizontal channel: steel scotch brite.

Finishing sides: steel scotch brite, thickness 4".

Top: steel scotch brite, thickness 2 1/4", String profile steel scotch brite, thickness 1/4".

Plinth: steel scotch brite.

Drawers and pull-out sides: brown painted.

Equipment Wave for drawers: solid wood thermo-treated oak, steel and linoleum.

Base units d 33"

Structural elements: lavagna grey melamine.

Doors: lite oak, horizontal and vertical vein.

Horizontal channel: lite oak.

Terminal vertical channel: lite oak, thickness 1".

Top: marble classic Travertine mat, thickness 2 1/4", String profile steel scotch brite, thickness 1/4".

Back: marble classic Travertine mat, thickness 3/4" and steel scotch brite, thickness 3/4".

Shelf: marble classic Travertine mat, thickness 2 1/4" and steel scotch brite thickness 1/4".

Plinth: lite oak.

Dress System: drawers and pull-out with anodized moka sides, inner finish in black elm.

Equipment for drawers: black elm.

Wall Units d 20"

Structural elements: lavagna grey melamine.

Doors: lite oak, horizontal and vertical vein.

Horizontal channel: rovere lite

Terminal vertical channel: lite oak, thickness 1".

Shelves: fume glass with frame anodized nero, thickness 1 1/4", integrated Dual color multi-led horizontal lighting.

Panel under Wall unit: steel scotch brite, thickness 1/4", integrated Dual color multi-led horizontal lighting.

Boiserie Harp

Panel: lite oak, horizontal and vertical vein,

String profile steel scotch brite.

Full High tall units d 29 1/4"

Structural elements: lavagna grey melamine.

Doors: lite oak, horizontal and vertical vein.

Vertical channel: lite oak, String profile steel scotch brite.

Plinth: lavagna grey melamine h 4".

Pivot Kitchen

Jamb profile: mat lacquer moka

Portal: lite oak with finishing sides thickness 3 1/4".

Side doors: fume reflective glass with

handle Side and frame in mat lacquer moka.

Ghost tall unit d 29 1/4"

Structure and inner doors: black elm.

Doors: lite oak, horizontal and vertical vein,

String profile steel scotch brite.

Plinth: embossed lacquer moka, h 4".

Dress System: drawers and pull-out with

anodized moka sides, inner finish in black elm.



rovere lite
lite oak



travertino classico
marmo
marble



acciaio scotch brite
steel scotch brite



laccato goffrato moka
embossed lacquer moka



5059 fume
vetro riflettente
reflecting glass



mat lacquer moka

Cucina Harp
Harp kitchen

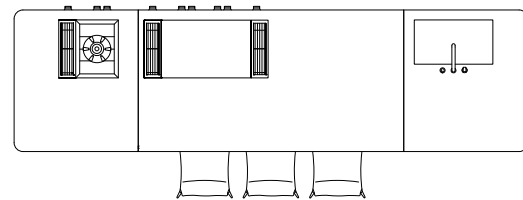
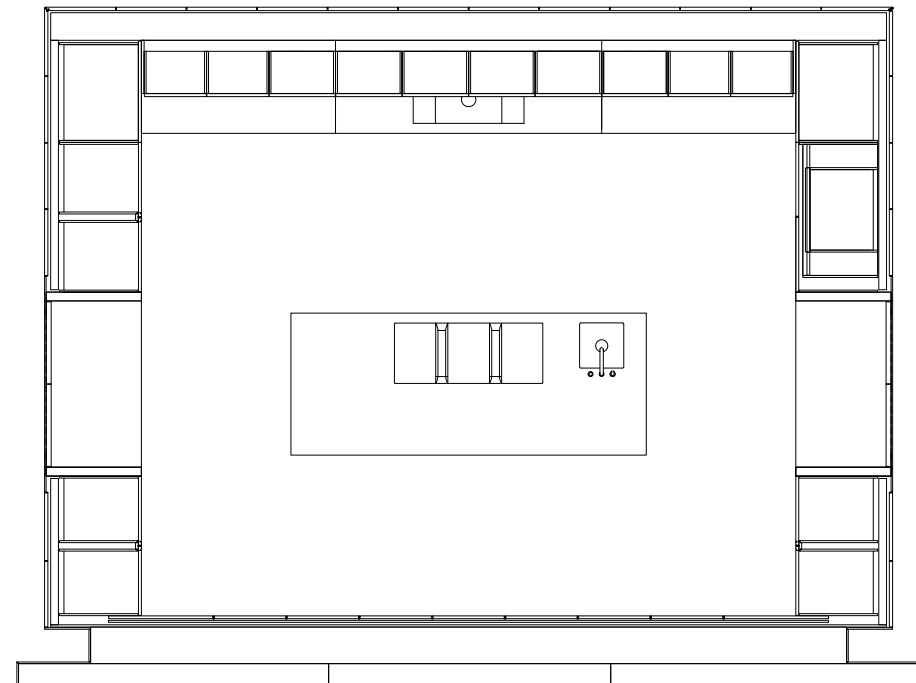

Isola, snack
Island, snack

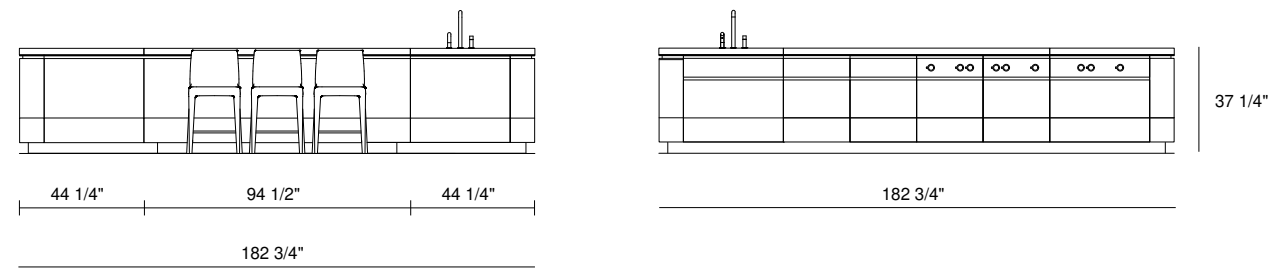

Isola
Island

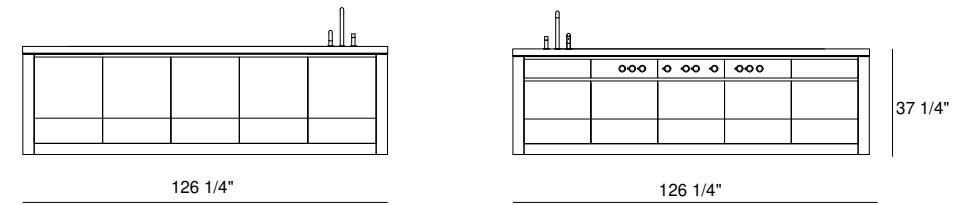

Basi, pensili
Base units, wall units

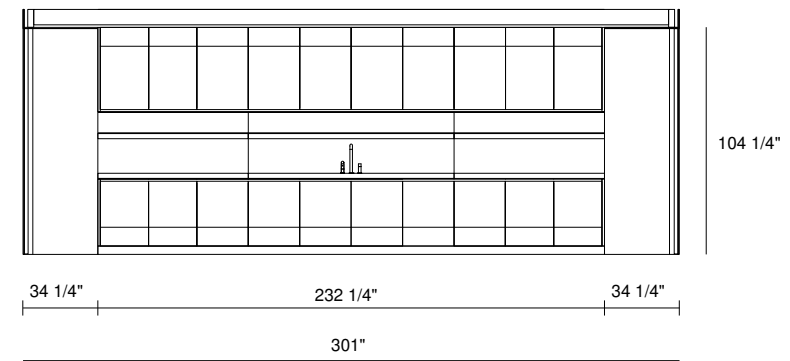

Boiserie Harp
Harp wall panelling

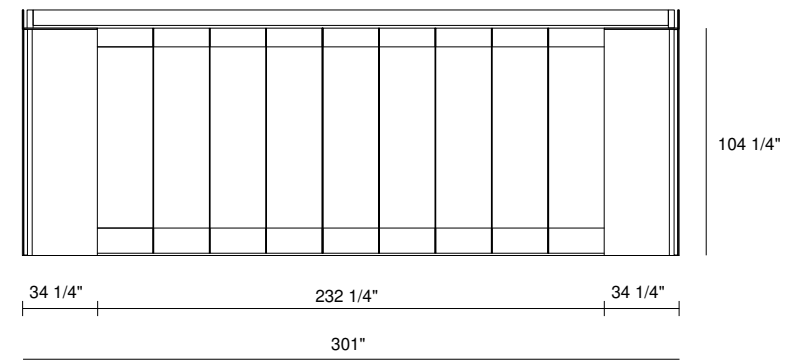

Colonne Full High, Pivot Kitchen
Full High tall units, Pivot Kitchen

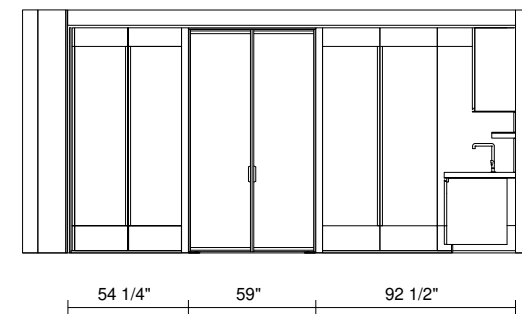

Colonne Full High, Colonne Ghost, Pivot Kitchen
High tall units, Ghost tall units, Pivot Kitchen

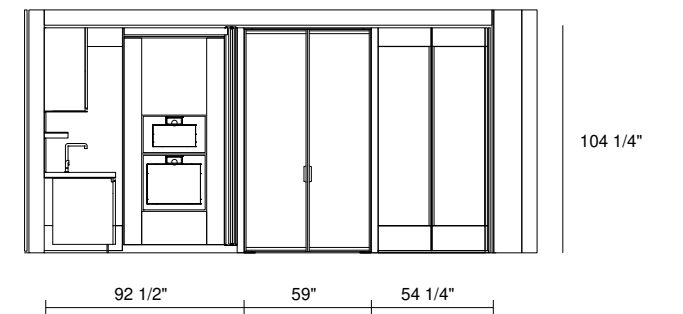

OUTDOOR COLLECTION

The outdoor collection expands with new elements designed for life outdoors. Jean-Marie Massaud introduces a sofa inspired by natural forms that, together with the coffee tables, evokes a nautical aesthetic and encourages a relaxed, informal way of living outside. Emmanuel Gallina designs a dining setting defined by refined material combinations, along with a sunbed that brings a warm, sophisticated presence to the poolside. An outdoor lamp by studioutte and a rug complete a space designed with consistent attention to every detail.

OUTDOOR COLLECTION

SHORE SOFA	315
SHORE COFFEE TABLE	345
CURVE TABLE	355
PONTE CHAIR	367
HENRY SUNBED	377
LIES LAMP	389
BRAID CARPET	395
NEW OUTDOOR FABRICS	401
OUTDOOR PROPOSALS	405
TECHNICAL DATA	423



SHORE SOFA

Shore invites you to slow down and experience the outdoors as a place of calm and wellbeing. The sofa's silhouette forms

grates effortlessly with the landscape while allowing light and air to filter through. The structure is made from hand-woven rope that recalls the motion of the waves, evoking a maritime atmosphere and a relaxed, informal approach to outdoor living.





This and previous pages: Shore sofa with removable cover in fabric Versailles 01 neve, cushions in fabric Mojave 01 corda, backrest and armrest in rope sabbia, feet in solid teak.





This and next page: Shore sofa with removable cover in fabric Sechura 05 grafite, cushions in fabric Karakum 11 grafite, backrest and armrest in rope grafite, feet in solid teak.



This and next page: Shore sofa with removable cover in fabric Sechura 05 grafite, cushions in fabric Nashi 03 grafite, backrest and armrest in rope sabbia, feet in solid teak.

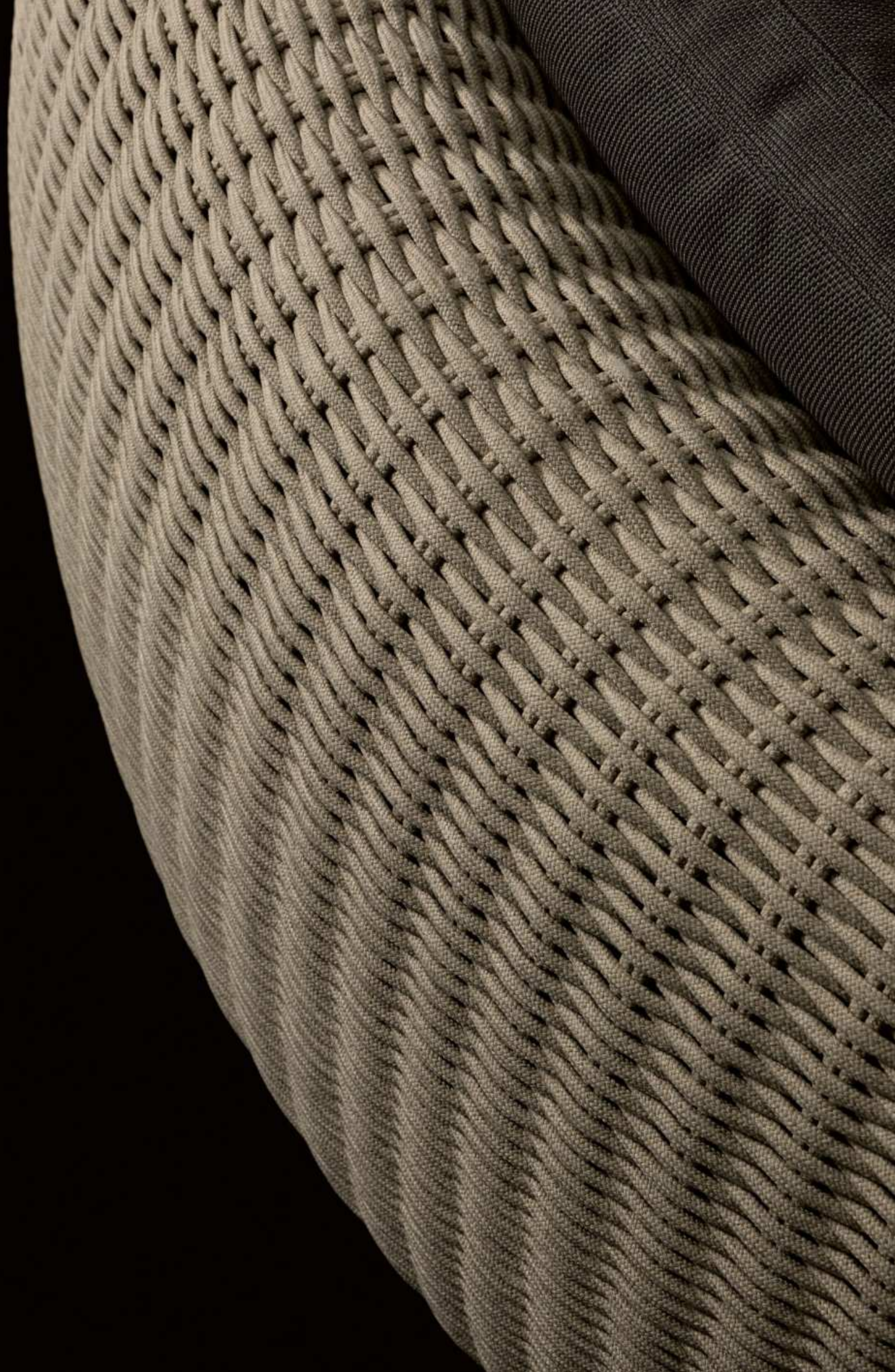





This and next page: Shore sofa with removable cover in fabric Mojave 01 corda, cushions in fabric Nashi 30 muschio and Karakum 15 muschio, backrest and armrest in rope sabbia, feet in solid teak.



This page: close up of the Shore sofa with removable cover in fabric Karif 02 burro, cushions in fabric Ghibli 02 taupe.



This page: Shore sofa with removable cover in fabric Karif 02 burro, cushions in fabric Ghibli 02 taupe, backrest and armrest in rope testa di moro, feet in solid teak.



This page: close up of the Shore armchair with removable cover in fabric Karif 02 burro, backrest and armrest in rope sabbia, feet in solid teak.





This page: Shore armchair with removable cover in fabric Karif 02 burro, cushion in fabric Ghibli 02 taupe, backrest and armrest in rope sabbia, feet in solid teak.

SHORE

in alluminio verniciato rivestito in corda
grafite. Prerivestimento in fibra di poliestere idrorepellente.
Rivestimento sfoderabile in tessuto.

covered in braided rope in the colours sabbia, testa di moro and grafite.
Pre cover in water-repellent polyester fiber.
Removable cover in fabric.

Divano inclinato
Angled sofa

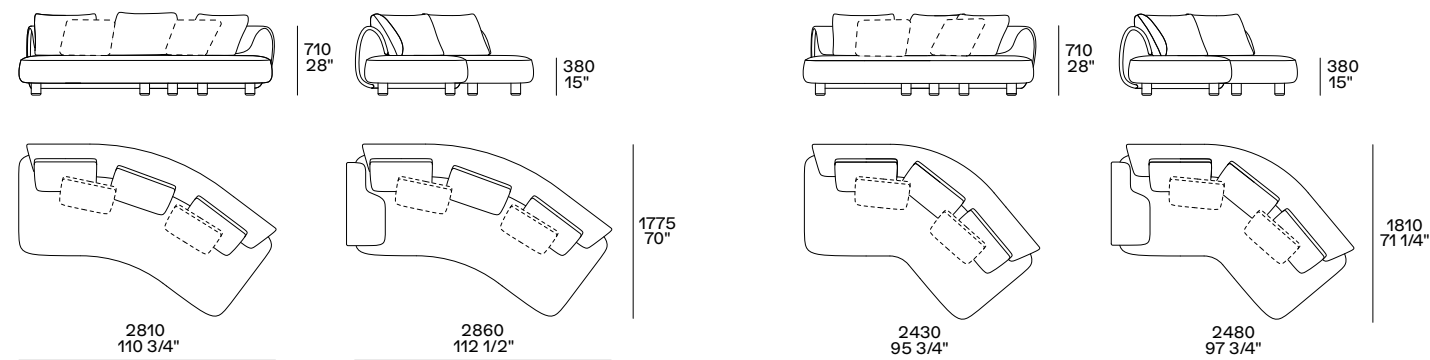

Elemento I 1260/1310
Element w 49 1/2"/51 1/2"

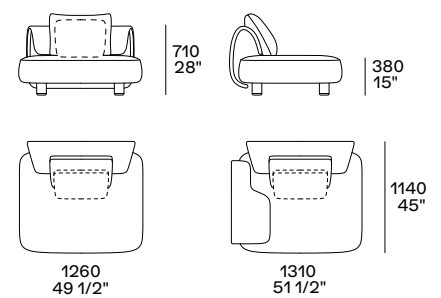

used as armchair

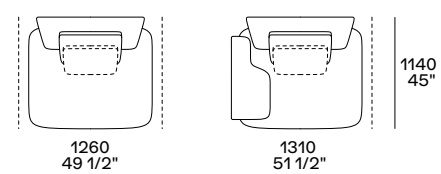

o centrale
used as lt-rt end unit
or central unit

used as lt-rt end unit

Bracciolo
Armrest

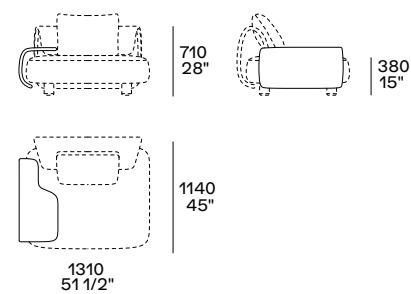
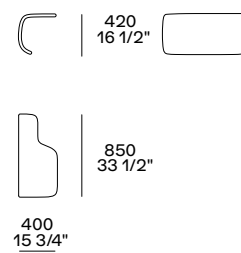

bracciolo terminale sx-dx, sporgenza 50
lt-rt armrest, protrusion 50

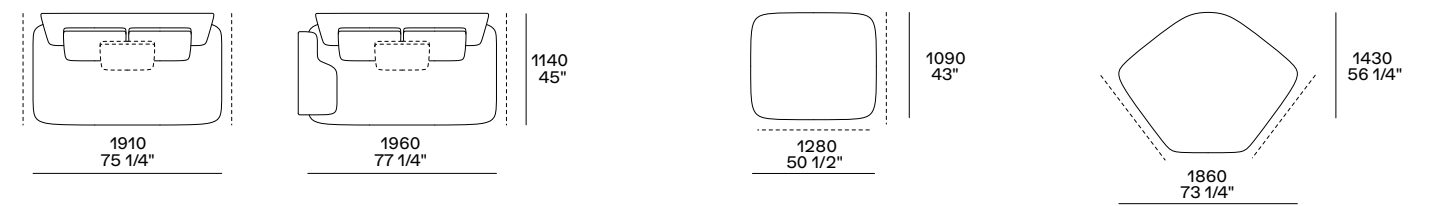

central unit

or freestanding

used as lt-rt angled end unit, corner unit, freestanding or daybed

Elementi inclinati
Angled units

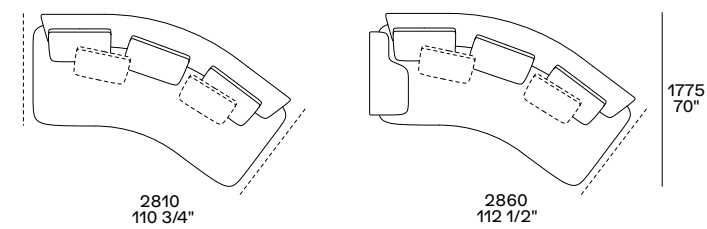

o centrale inclinato
used as lt-rt angled end unit or
angled central unit

used as lt-rt angled end unit

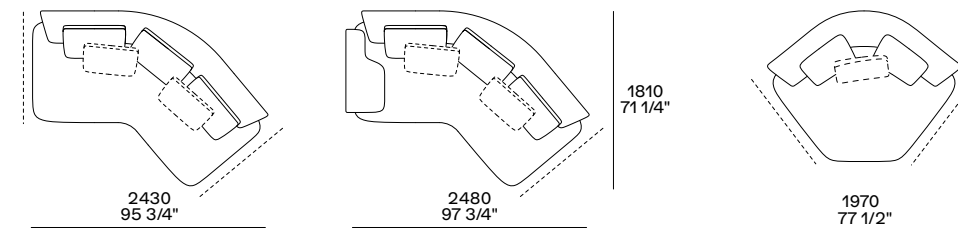

o centrale inclinato
used as lt-rt angled end unit
or angled central unit

used as lt-rt angled end unit

centrale, angolare o daybed
used as lt-rt angled end unit,
central unit, corner unit or daybed

Daybed
Daybed

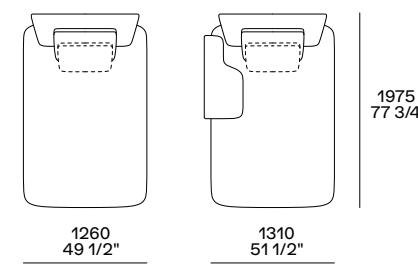

uso centrostanza
used as freestanding

Chaise longue
Chaise longue

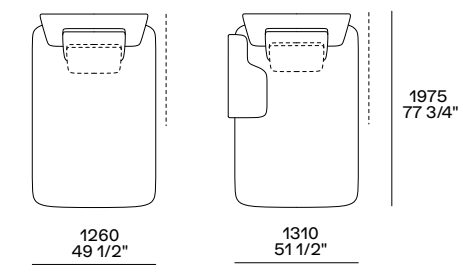

used as lt-rt end unit

Cuscino opzionale
Optional cushion

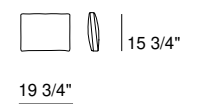

SHORE COFFEE TABLE

Accompanying the Shore sofa are coffee tables whose distinctive tops recall the reflections of light on the surface of water. Available in a range of sizes, including a version designed to be placed beside the sofa, they can be combined to create flexible compositions.





This and next page: Shore coffee tables with top and base in glossy glazed gres in colour burro and legs in solid teak. Previous pages: Shore coffee tables with top in glossy glazed gres in the colours alloro and grafite, legs in solid teak.





SHORE

gres smaltato lucido nei colori burro, alloro e grafite.

glazed gres in the colours burro, alloro and grafite.

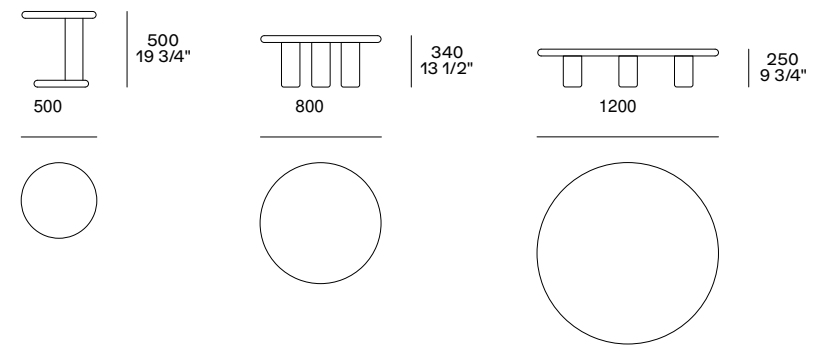

CURVE TABLE



design is defined by a new interplay of materials: the table is crafted in fine teak, with either a slatted or ceramic top, while the wooden crosspiece - a feature also found in the indoor version - is wrapped in rope, a reference to the world of sailing.

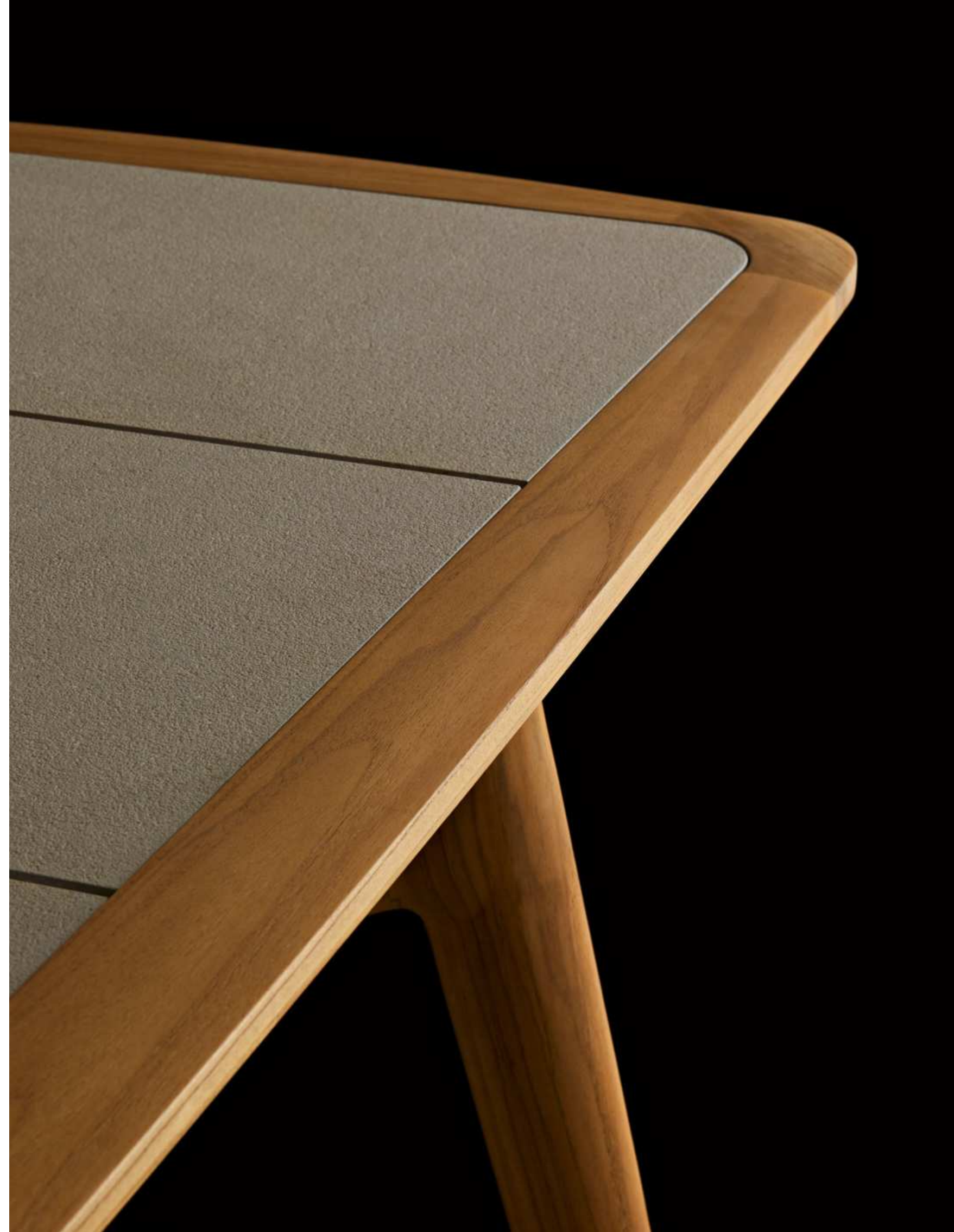

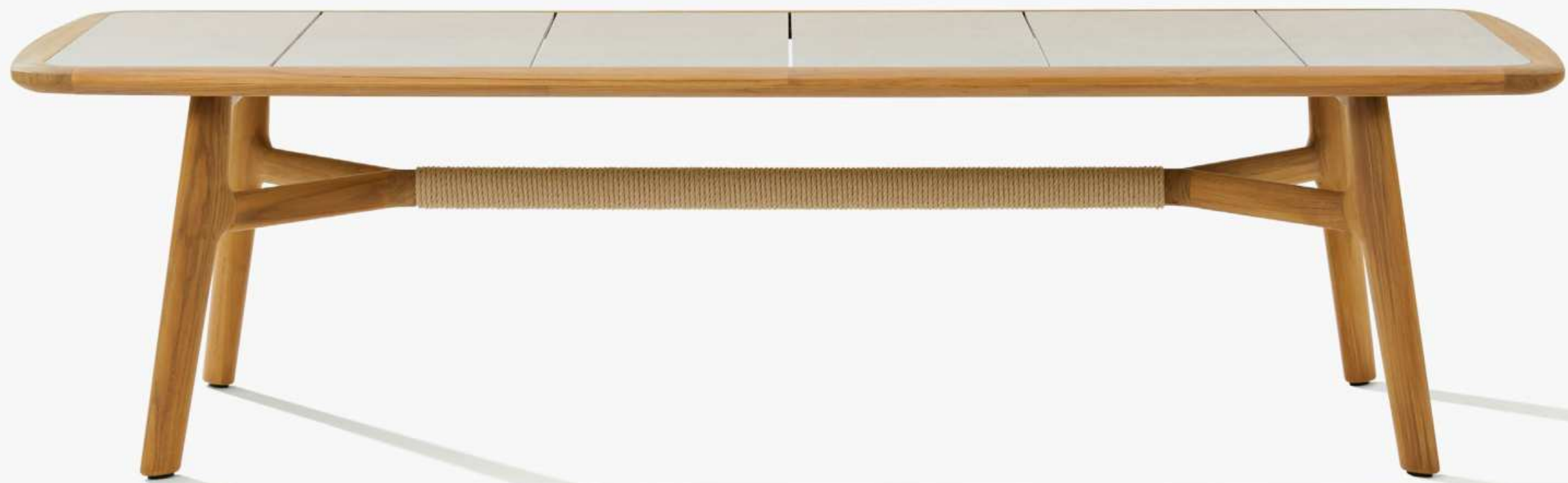



This and next page: Curve table with top and structure in solid teak, crossbar covered in twisted rope naturale. Previous pages: Curve table with structure in solid teak, crossbar covered in twisted rope naturale, top in solid teak and mat gres burro.



CURVE

stessa finitura rivestito in corda mattone, testa di moro o in corda ritorta naturale. Piano in teak o in gres opaco burro.

Structure in solid teak, crossbar in the same finish covered in rope matrone, testa di moro or in twisted rope naturale. Top in teak or in mat gres burro.

Piano in legno Top in wood

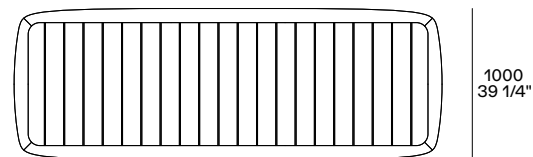
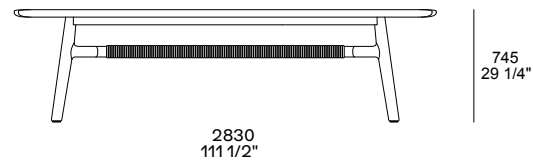
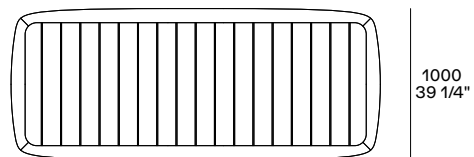
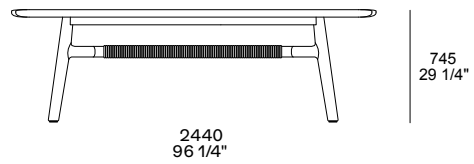
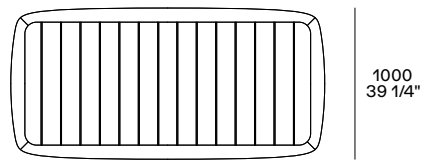
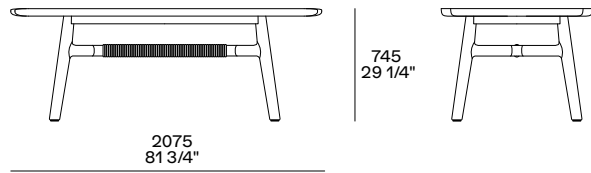

Piano in gres Top in gres

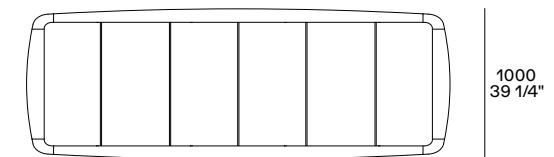
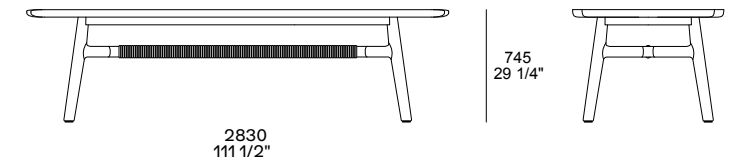
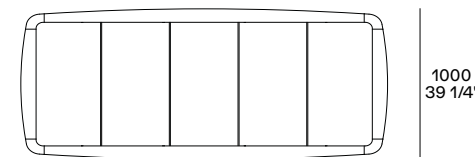
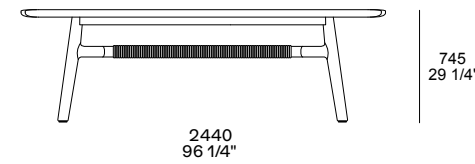
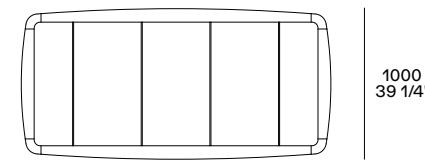
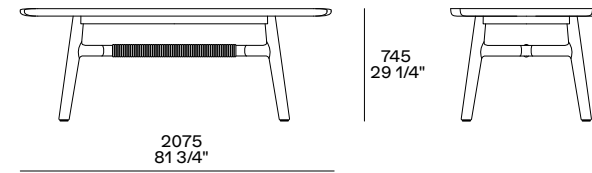



PONTE CHAIR

Completing the Ponte collection, designed by Emmanuel Gallina and inspired by the elegance of the nautical world, is the chair of the same name, created for outdoor dining. As with the Curve table it accompanies, the teak structure is enhanced by rope detailing, as well as by the fabric covering the seat and back cushions.

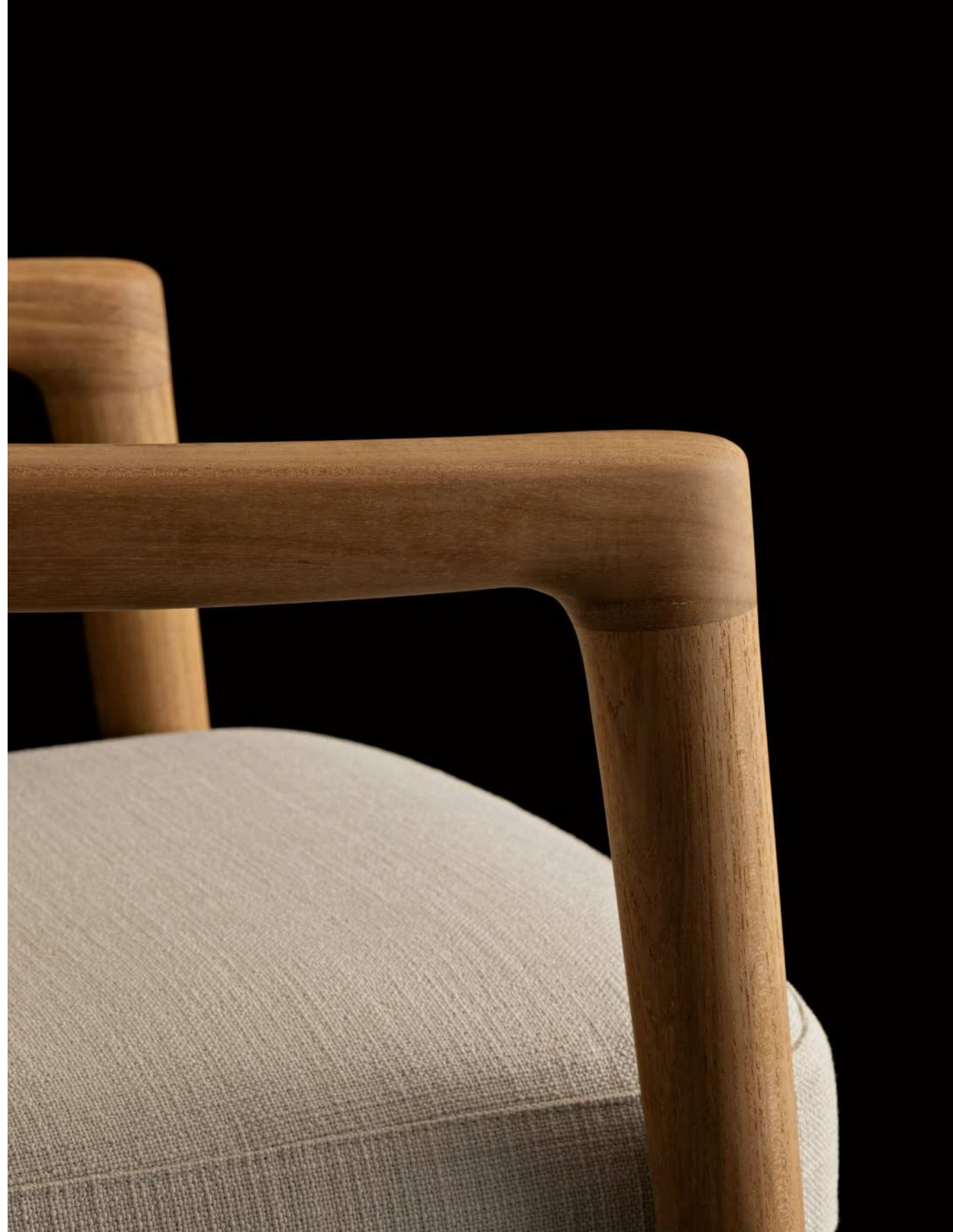



This and next page: Ponte chair with structure in solid teak and backrest in twisted rope naturale, removable cover in fabric Sechura 10 mattone. Previous pages: Ponte chair with structure in solid teak and backrest in twisted rope naturale, removable cover in fabric Karif 02 burro.





PONTE

Design Emmanuel Gallina

in corda mattone e testa di moro o in corda ritorta naturale.

Cuscino seduta e schienale in poliester riciclato PET con inserto in poliuretano

Prerivestimento in fibra di poliester.
Rivestimento sfoderabile in tessuto.

Structure in solid teak, backrest in painted stainless steel tubular frame, covered in rope mattone and testa di moro or in twisted rope naturale.

Seat cushion and backrest in recycled polyester PET with insert in polyurethane foam with differentiated densities.

Pre-cover in polyester fiber.
Removable fabric cover.

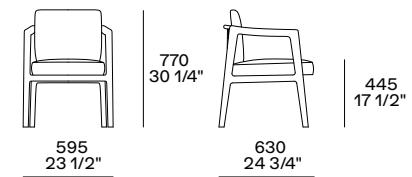



HENRY SUNBED

behind a light, understated aesthetic. The structure is made of aluminium and teak, a material with a warm, refined character that remains visible beneath the cushion. The backrest adjustment mechanism is completely hidden, while the wheels are integrated into the structure.





This and next pages: Henry sunbed with structure in embossed painted aluminium casting oxid and slats in solid teak, wheels in rubber and oxid embossed painted aluminium. Removable cover in fabric Ghibli 04 sabbia. Headrest cushion in fabric Ghibli 04 sabbia. Previous pages: Henry sunbed with structure in embossed painted aluminium casting oxid and slats in solid teak, wheels in rubber and oxid embossed painted aluminium. Removable cover in fabric Versailles 01 neve. Headrest cushion in fabric Versailles 01 neve.







HENRY

in legno massello. Schienale reclinabile.
 Ruote in gomma nera antisegno e alluminio
 verniciato goffrato oxid.
 Cuscino seduta e schienale in poliestere
 riciclato PET. Poggiatesta in poliuretano.
 Prerivestimento in fibra di poliestere
 idrorepellente.
 Rivestimento sfoderabile in tessuto.

casting in the colours sabbia and oxid,
 slats in solid teak. Reclining backrest.
 Black rubber non-marking wheels and oxid
 embossed painted aluminium.
 Seat and backrest cushion in recycled
 polyester PET. Headrest in polyurethane.
 Pre-cover in water-repellent polyester
 fiber.
 Removable cover in fabric.

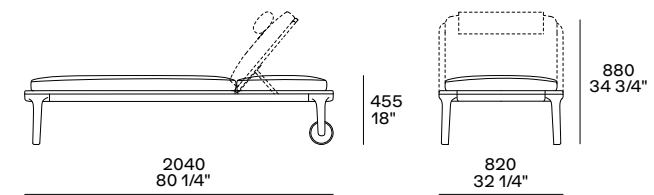

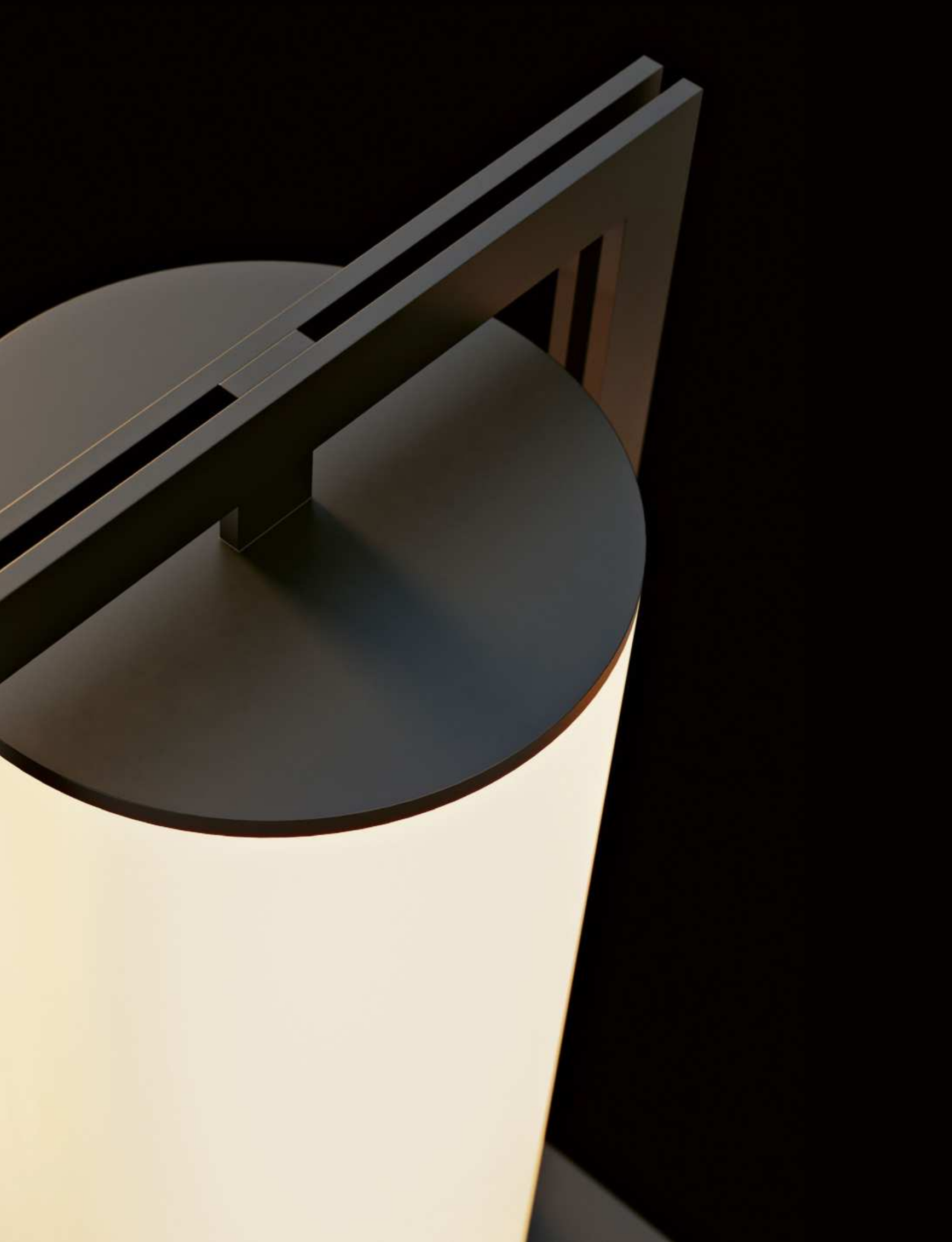

LIES LAMP

lanterns. Originally used as offerings of light and later becoming an essential feature of East Asian gardens, lanterns evoke a quiet, meditative way of experiencing the outdoors. In studioutte's interpretation, the lines are pared back and precise, transforming the lantern into an elegant, contemporary lamp.





LIES
Design studioutte

opaco. Corpo illuminante in metacrilato
dimmerabile.

Structure in mat carbone painted metal.
Light fixture with satin opal methacrylate
body. Dimmable led light 2700K.

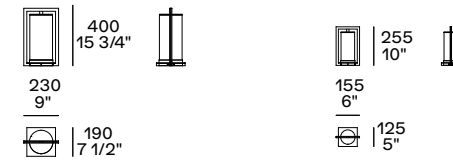

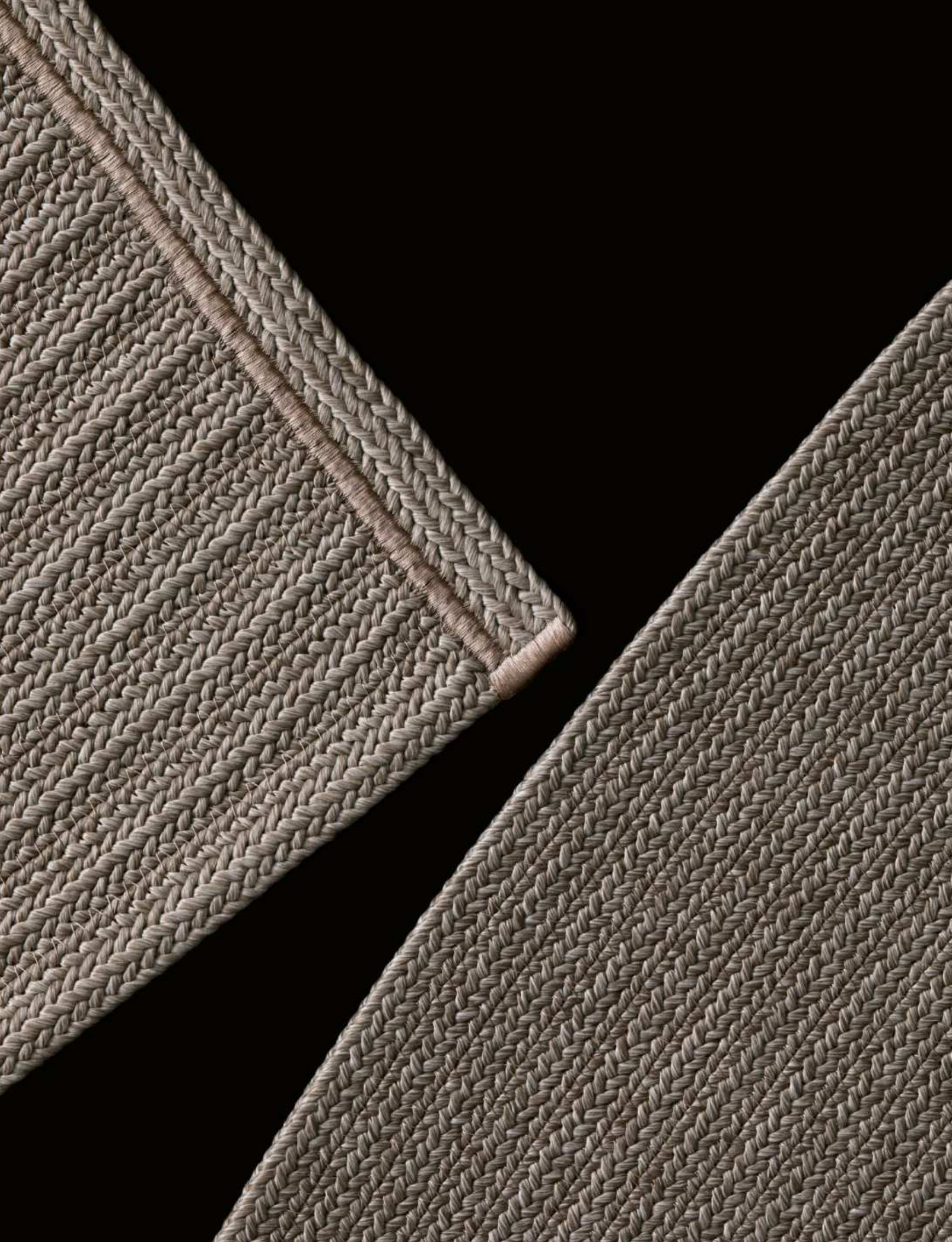

BRAID CARPET

Braid is an outdoor rug made from an innovative fibre woven version. Resistant to sun and water, it has a natural aesthetic that enriches outdoor spaces and complements all the pieces in the collection.

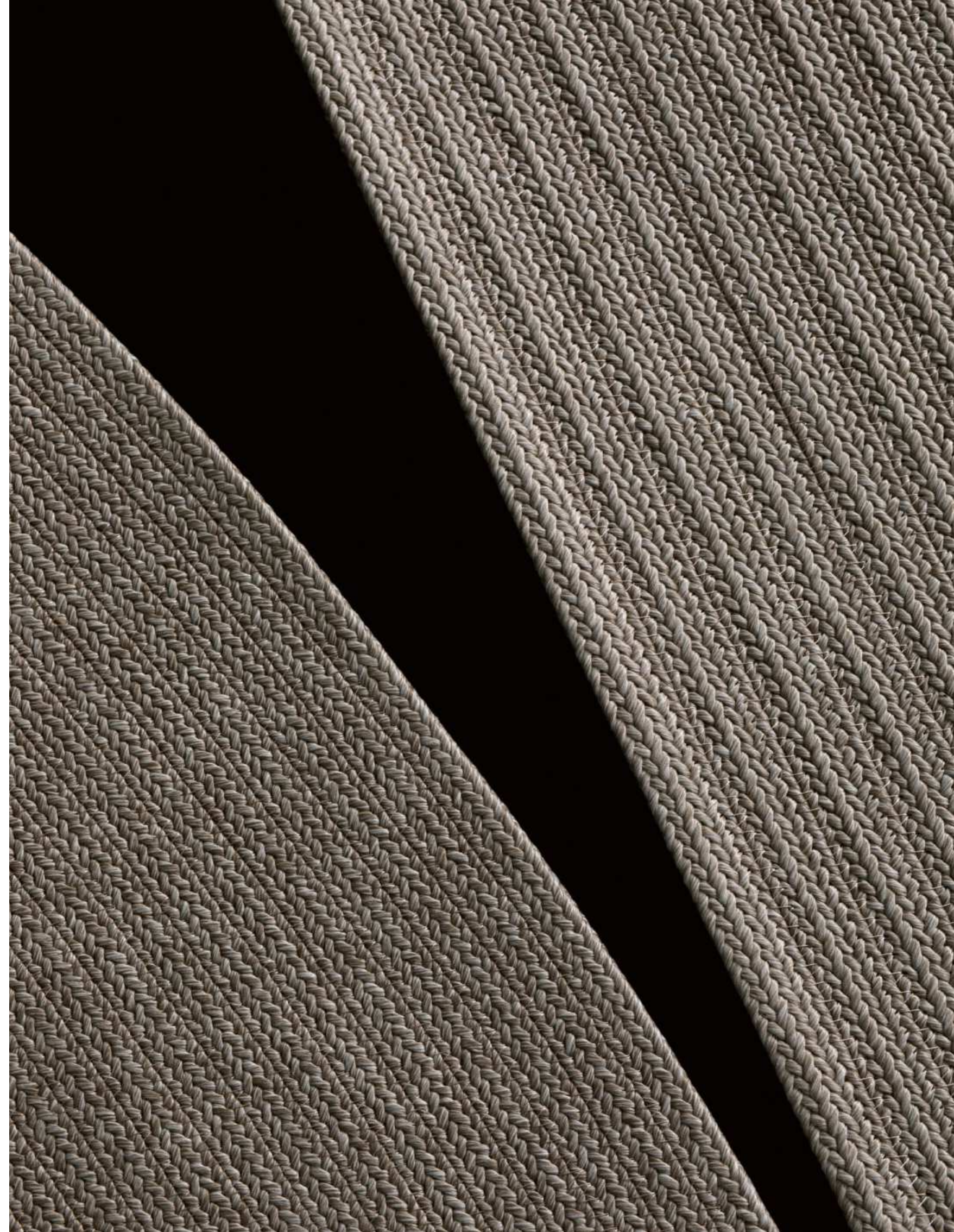



BRAID

Dimensioni mm: rettangolare 2000×3000
3000×4000 - 2500×3500
quadrato 3000x3000 - rotondo 2500.

Carpet resistant to water, chlorine, and light,
anti-allergic.
Dimensions in: rectangular 78 3/4"x118"
118"x157 1/2" - 98 1/2"x137 3/4"
square 118x118 - round 98 1/2".

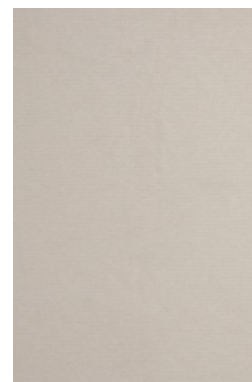

Sabbia

NEW OUTDOOR FABRICS

Completing the collection is a new chenille-effect fabric, characterised by a low, even pile and a soft hand. Suitable for all outdoor products, the fabric brings the same tactile qualities as indoor upholstery to outdoor settings.

NUOVI TESSUTI OUTDOOR NEW OUTDOOR FABRICS



01 neve



02 sabbia



03 grafite

OUTDOOR PROPOSALS

COMPOSITION 01	406
COMPOSITION 02	408
COMPOSITION 03	410
COMPOSITION 04	412
COMPOSITION 05	414
COMPOSITION 06	416
COMPOSITION 07	418
COMPOSITION 08	420



COMPOSITION 01

in tessuto Mojave 06 mattone, schienale e bracciolo in corda sabbia,

dimmerabile. Tappeto Kamir ecru.

Shore sofa and armchair in removable fabric Nashi 05 corda, cushions
in fabric Mojave 06 mattone, backrest and armrest in rope sabbia,
feet in solid teak. Reef coffee tables in Cementoraw mattone and
crema. Lies lamp in mat carbone painted metal with dimmable LED
light. Carpet Kamir ecru.



COMPOSITION 02

e base in gres smaltato lucido nel colore grafite e gambe in massello
dimmerabile. Tappeto Kamir ecru.

Shore sofa and armchair in removable fabric Versailles 01 neve, cushions in fabric Mojave 03 grafite, backrest and armrest in rope grafite, feet in solid teak. Shore pouf in removable fabric Versailles 01 neve, feet in solid teak. Shore coffee tables with top and base in glossy glazed gres in the colour grafite and legs in solid teak. Lies lamps in mat carbone painted metal with dimmable LED light. Carpet Kamir ecru



COMPOSITION 03

in gres smaltato lucido nel colore burro e gambe in massello di teak.
rabile. Tappeto Braid sabbia.

Shore sofa and armchair in removable fabric Versailles 01 neve, cushions in fabric Mojave 01 corda, backrest and armrest in rope sabbia, feet in solid teak. Shore coffee tables with top and base in glossy glazed gres in the colour burro and legs in solid teak. Lies lamp in mat carbone painted metal with dimmable LED light. Carpet Braid sabbia.



COMPOSITION 04

merabile. Tappeto Braid sabbia.

Shore sofa and armchair in removable fabric Versailles 03 grafite, cushions in fabric Nashi 03 grafite, backrest and armrest in rope sabbia, feet in solid teak. Reef coffee tables in Cementoraw crema. Lies lamps in mat carbone painted metal with dimmable LED light. Carpet Braid sabbia.



COMPOSITION 05

scini in tessuto Ghibli 01 tabacco, schienale e bracciolo in corda te-
dimmerabile. Tappeto Braid sabbia.

Shore sofa and armchair in removable fabric Karif 04 tabacco, cush-
ions in fabric Ghibli 01 tabacco, backrest and armrest in rope testa
di moro, feet in solid teak. Reef coffee tables in Cementoraw cre-
ma. Lies lamp in mat carbone painted metal with dimmable LED light.
Carpet Braid sabbia.



COMPOSITION 06

scini in tessuto Nashi 30 muschio e Karacum 15 muschio, schienale
con piano e base in gres smaltato lucido nel colore alloro e gambe in

Shore sofa and armchair in removable fabric Mojave 01 corda, cushions in fabric Nashi 30 muschio and Karacum 15 muschio, backrest and armrest in rope sabbia, feet in solid teak. Shore coffee tables with top and base in glossy glazed gres in the colour alloro and legs in solid teak. Lies lamp in mat carbone painted metal with dimmable LED light. Carpet Kamir corda.



COMPOSITION 07

ni in tessuto Ghibli 02 taupe, schienale e bracciolo in corda testa di
smaltato lucido nei colori grafite e burro, gambe in massello di teak.
rabile. Tappeto Braid sabbia.

Shore sofa and armchair in removable fabric Karif 02 burro, cushions
in fabric Ghibli 02 taupe, backrest and armrest in rope testa di moro,
feet in solid teak. Shore coffee tables with top and base in glossy
glazed gres in the colours grafite and burro, legs in solid teak. Lies
lamp in mat carbone painted metal with dimmable LED light. Carpet
Braid sabbia.



COMPOSITION 08

gres smaltato lucido nei colori grafite e burro, gambe in massello di
dimmerabile. Tappeto Braid sabbia.

Shore sofa and armchair in removable fabric Sechura 05 grafite, cushions in fabric Karacum 11 grafite, backrest and armrest in rope grafite, feet in solid teak. Shore coffee tables with top and base in glossy glazed gres in the colours grafite and burro, legs in solid teak. Lies lamps in mat carbone painted metal with dimmable LED light. Carpet Braid sabbia.

FINITURE OUTDOOR
OUTDOOR FINISHINGS

Massello
Solid wood



teak



iroko tinto nero
black stained iroko

EVA (espanso vinilico acetato)
EVA (expanded vinyl acetate)



ghiaccio



nocciola



testa di moro



oliva

Parti metalliche
Metal parts



sabbia
mat painted



mattone
mat painted



brown nickel
mat painted



sabbia
verniciato goffrato
embossed painted



oxid
verniciato goffrato
embossed painted

Cementoskin
Cementoskin



crema



tortora



grafite

Cementoraw
Cementoraw



crema



menta



terracotta

Pietra lavica
Lava stone



roccia



nera

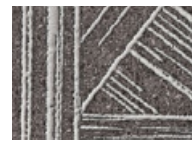

roccia



nera

Pietra spatolata
Spatula finish stone



arena



tortora

Gres smaltato lucido
Glossy glazed gres



crema



burro ●



alloro ●



salvia



grafite ●



bronzo

Gres smaltato opaco
Mat glazed gres

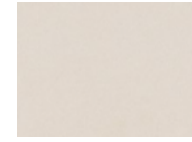

crema



menta



terracotta



burro ●

Gres opaco
Mat gres

Gres with glossy cast glass



crema



menta



terracotta

Mat and glossy glazed gres



sabbia



grafite

Vetrofusione
Fused glass



fume
fume



fume
fume

● news

FINITURE OUTDOOR
OUTDOOR FINISHINGS

**Corda
Rope**



sabbia



mattone



testa di moro



grafite



naturale

**Corda ritorta
Twisted rope**

**Fettuccia
Tape**



testa di moro

**Fettuccia larga
Large tape**



sabbia



mattone



testa di moro

**Libeccio tessuto intrecciato
Libeccio woven fabric**



ecru



visone



notte

**Tessuti
Fabrics**



mistral cat. d
5 colori - colours



shamal cat. d
11 colori - colours



karakum cat. g
8 colori - colours

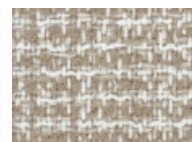

8 colori - colours



10 colori - colours



bris cat. g
4 colori - colours

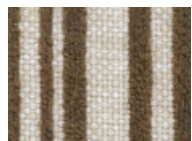

ghibli cat. g
4 colori - colours

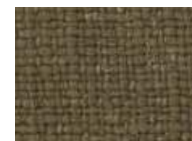

karif cat. g
5 colori - colours

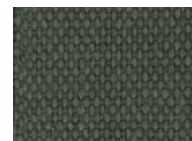

merak cat. g
8 colori - colours



nashi cat. g
8 colori - colours



versailles cat. g
3 colori - colours



zephiros cat. m
7 colori - colours

**Lampade
Lamps**



carbone opaco
mat carbone

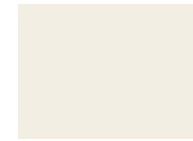

metacrilato
opalino satinato
satin opal
methacrylate

**Land
kitchen**



alluminio laccato
lacquered aluminium
structure and sides



Inalco MDi
11 carbone
fronts and covers

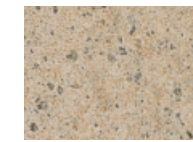

Inalco MDi
10 porfido beige
fronts and covers



Inalco MDi
12 camel lines
fronts and covers



acciaio - steel
barbecue and
accessories



massello di teak
solid teak
top and accessories

● news



All the Plankfist collections are manufactured in Italy using top-class components and materials.

Plankfist si riserva il diritto di apportare, senza preavviso, ogni modifica e disegni presenti in questo stampato hanno scopo divulgativo: per ogni

Plankfist reserves the rights at all time to apply modifications for the functional or qualitative improvement of its products. Texts and drawings present in this brochure have a divulgative purpose: for every technical and dimensional aspect please refer to the company's price lists and their relative updatings. The colour and material samples have an indicative value.

Creative Direction
Apartamento Studios

Graphic Design
Apartamento Studios

Still Life Photography
Silvia Orlandi

1st edition April 2026
cod. 151/R1/2026



ASSARREDO
FEDERLEGNOARREDO



TWO THOUSAND TWENTY SIX

PLANKFIST VENTURES PRIVATE LIMITED
Hi Lite Business Park, Flat Nos. 2/1149/1-86 & 87, Iringallur Road
Kozhikode, Kerala, India - 673014
Phone: +91 85902 77688
Email: hello@plankfist.com | sales.plankfist@gmail.com
Website: plankfist.com