

# NEWS 2025

**Plankfist**

**Plankfist**

ing and extending to outdoor spaces, pairing sofas, armchairs, chairs, and tables with a series of finely crafted pieces, curated like collectible objects. Bookshelves, desks, coffee tables, and lamps add a distinctive touch to a collection designed for versatility and cohesion, where style evolves into a lifestyle.

2025

COLLECTIONS

INDOOR COLLECTION

9

OUTDOOR COLLECTION

231

# INDOOR COLLECTION

complementary paths: the Joan sofa, defined by its minimalist design, and the Owen collection, which embraces the inviting aesthetics of Mid-Century style. The generous proportions of the Leopold armchair, the sculptural simplicity of the Joan coffee tables, and the light, essential design of the Tess bookcase all further elevate the space. Massaud also expands the Adrien collection with large dining tables, coffee tables, and a statement desk designed for the contemporary home office. Rounding out the Indoor collection are the swivel version of the Orbis armchair by Emmanuel Gallina and the Helga and Arthur lamps by studioutte-pieces that propel Plankfist's world into new, uncharted territories.

INDOOR COLLECTION	
JOAN SOFA	13
JOAN COFFEE TABLE	29
OWEN COLLECTION	47
LEOPOLD ARMCHAIR	65
ORBIS ARMCHAIR	77
ADRIEN COFFEE TABLE	87
TESS BOOKCASE	101
ADRIEN HOME DESK	113
ADRIEN TABLE	127
NARA COLLECTION	139
ARTHUR LAMP	153
HELGA LAMP	159
WALL SYSTEM	165
LINK SYSTEM	179
SENZAFINE	185
NEW INDOOR FABRICS	195
INDOOR PROPOSALS	199
TECHINICAL DATA	219

# JOAN SOFA

A quintessential sofa that distills form to the pure essence of comfort, putting upholstery at center stage. With Joan, Jean-Marie Massaud delves into minimalist design, drawing inspiration from the world of fashion. The sofa showcases clean lines, balanced proportions, and meticulous attention to materials, from tonal to contrast piping. The collection includes a variety of modular elements, including angled pieces, allowing for versatile compositions, whether expansive or more compact.







On this and on the next page: Joan sofa with removable cover in velvet Persia 2002 bruciato, coffee table in black elm, grosgrain border nero, mat brown nickel feet. On the previous pages: Joan sofa with removable fabric Konik 03 senape, cushions in velvet Polar 14 bronzo, grosgrain border cioccolato, mat brown nickel feet.



On this and on the next page: Joan sofa with removable fabric Shire 03 cenere, cushions in fabric Konik 01 bianco, grosgrain border nuvola, mat brown nickel feet.

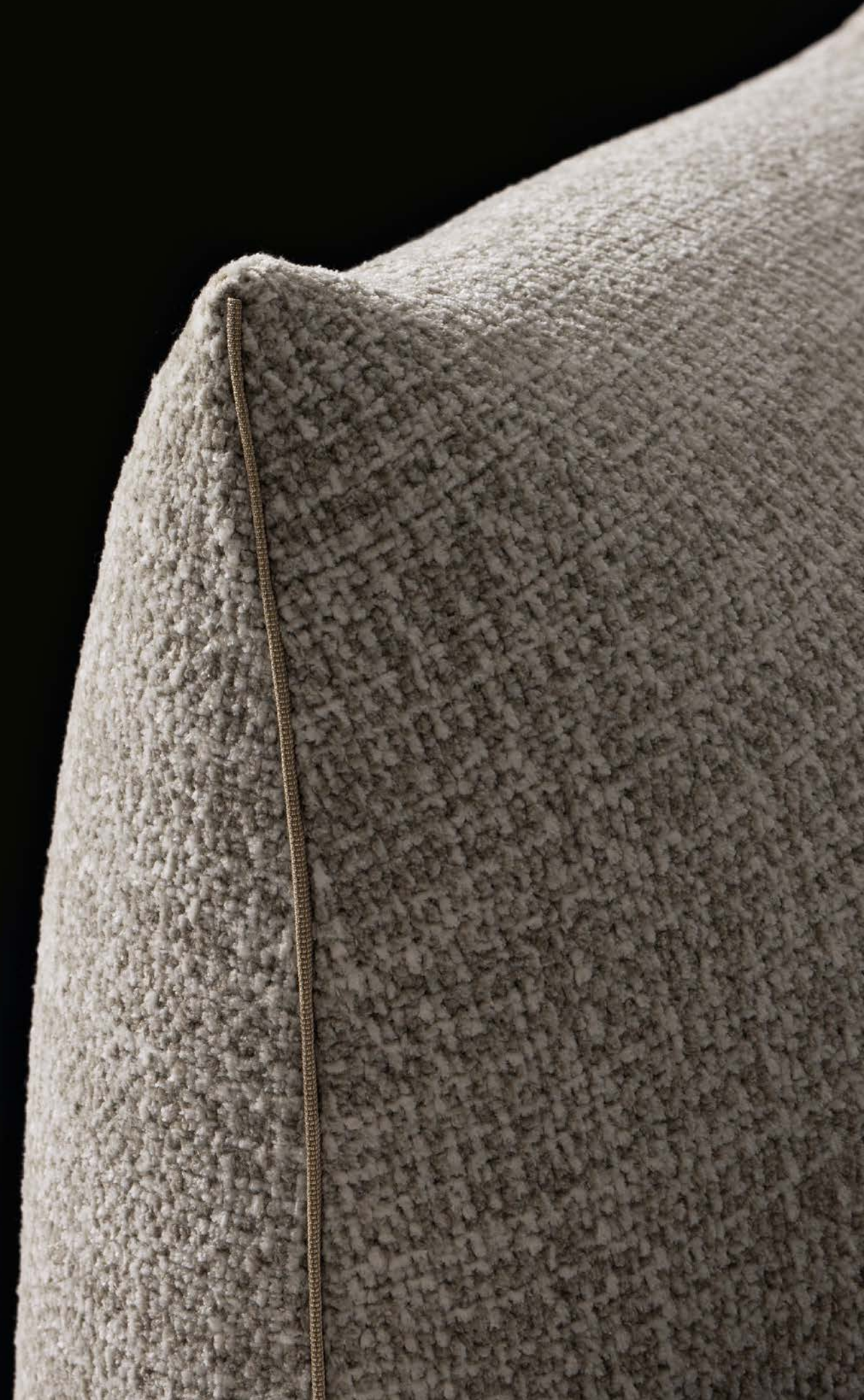



# JOAN

Struttura in legno e derivati e poliuretano a quote differenziate con prerivestimento in tela cotone e fibra di poliestere. Schienali in poliuretano flessibile stampato monoquota. Cuscini opzionali in tela cotone e fibra di poliestere.  
Piedini in fusione di alluminio verniciati brown nickel opaco.

Structure in wood and wood-derivatives and multi-density polyurethane with pre-cover in cotton canvas and polyester fibre. Backrests in single-density moulded flexible polyurethane. Optional cushions in cotton canvas and polyester fibre.  
Feet in aluminium casting in metal painted mat brown nickel.  
Removable cover in fabric or leather.  
In the fabric version, grosgrain border in the sample colours.  
End or central coffee table inserted between two elements of the sofa. Structure and top in medium density fibre board veneered in ash stained black elm, glossy lacquered colours or glossy steel.

elementi del divano. Struttura e piano in impiallacciato frassino tinto olmo nero,

## Divano Sofa

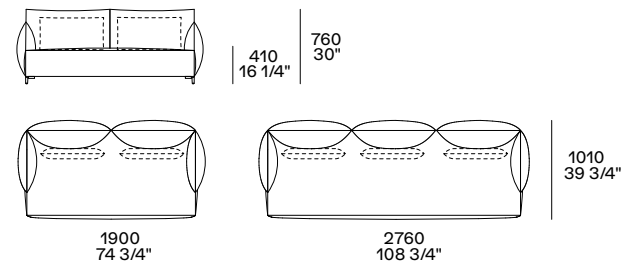

## Poltrona Armchair

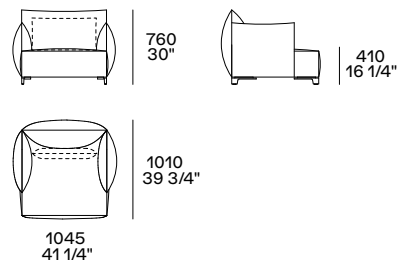

## Sofa with high armrest

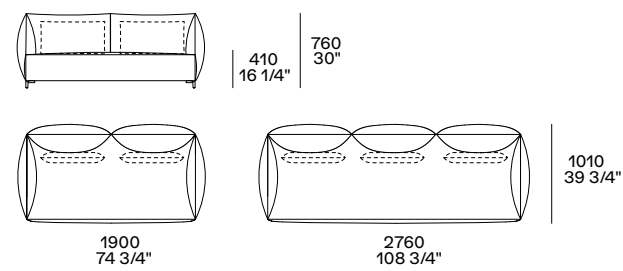

## Armchair with high armrest

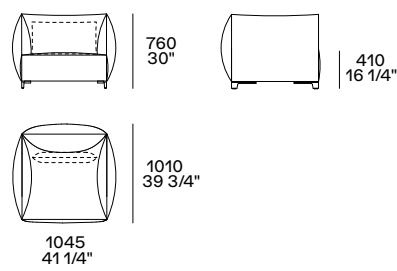

## Terminale sx-dx Lt-rt end unit

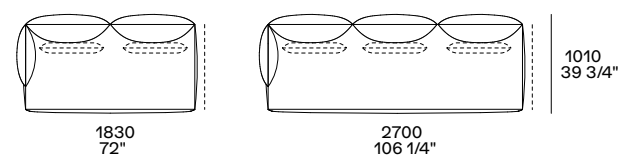

## Terminale penisola sx-dx Lt-rt peninsula end unit

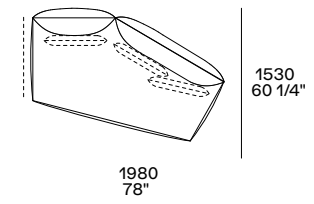
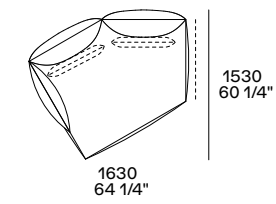
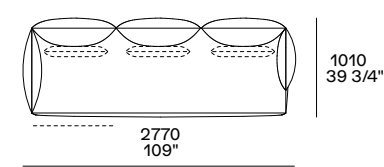
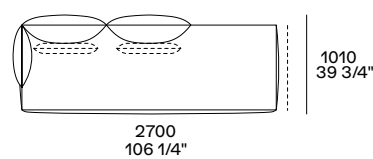

## Centrale Central unit

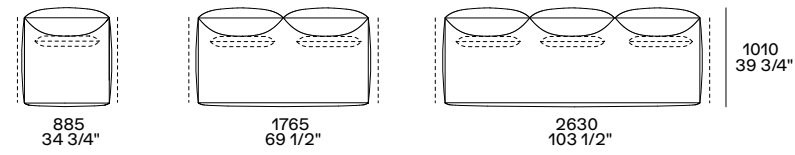

## Centrale penisola sx-dx Lt-rt peninsula central unit

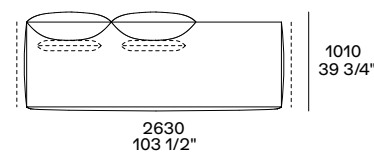

## Centrale inclinato Angled central unit

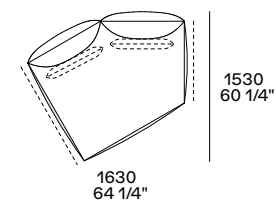

## Chaise longue Chaise longue

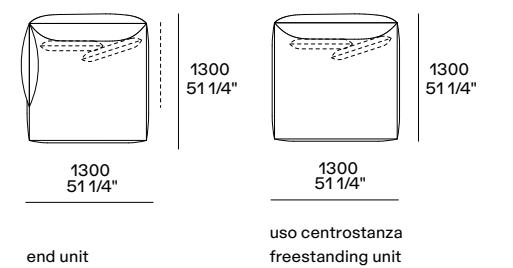

## Angolo sx-dx Lt-rt corner unit

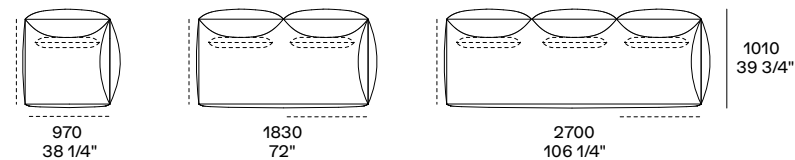

also used as end unit

## Angolo penisola sx-dx Lt-rt peninsula corner unit

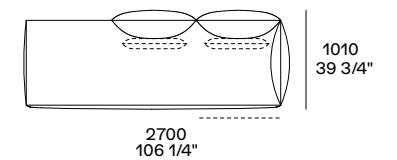

also used as freestanding unit

## Pouf Pouf

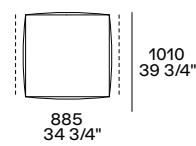

used as end unit, central unit or freestanding unit

## Cuscino opzionale Optional cushion

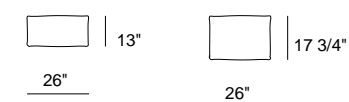

## Tavolino Coffee table

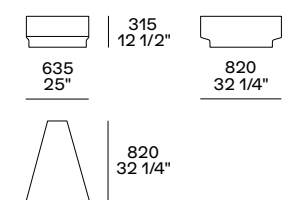

Coffee table (except chaise longue) or inserted between two elements of the sofa.

# JOAN COFFEE TABLE

Like the sofas they complement, the Joan coffee tables

ist design philosophy. Available in various sizes-perfect as

transcend their function to become sculptural objects. Their versatility is further enhanced by the possibility of mixing and matching different shapes and finishes, from steel to wood to lacquer, creating dynamic and personalized compositions.

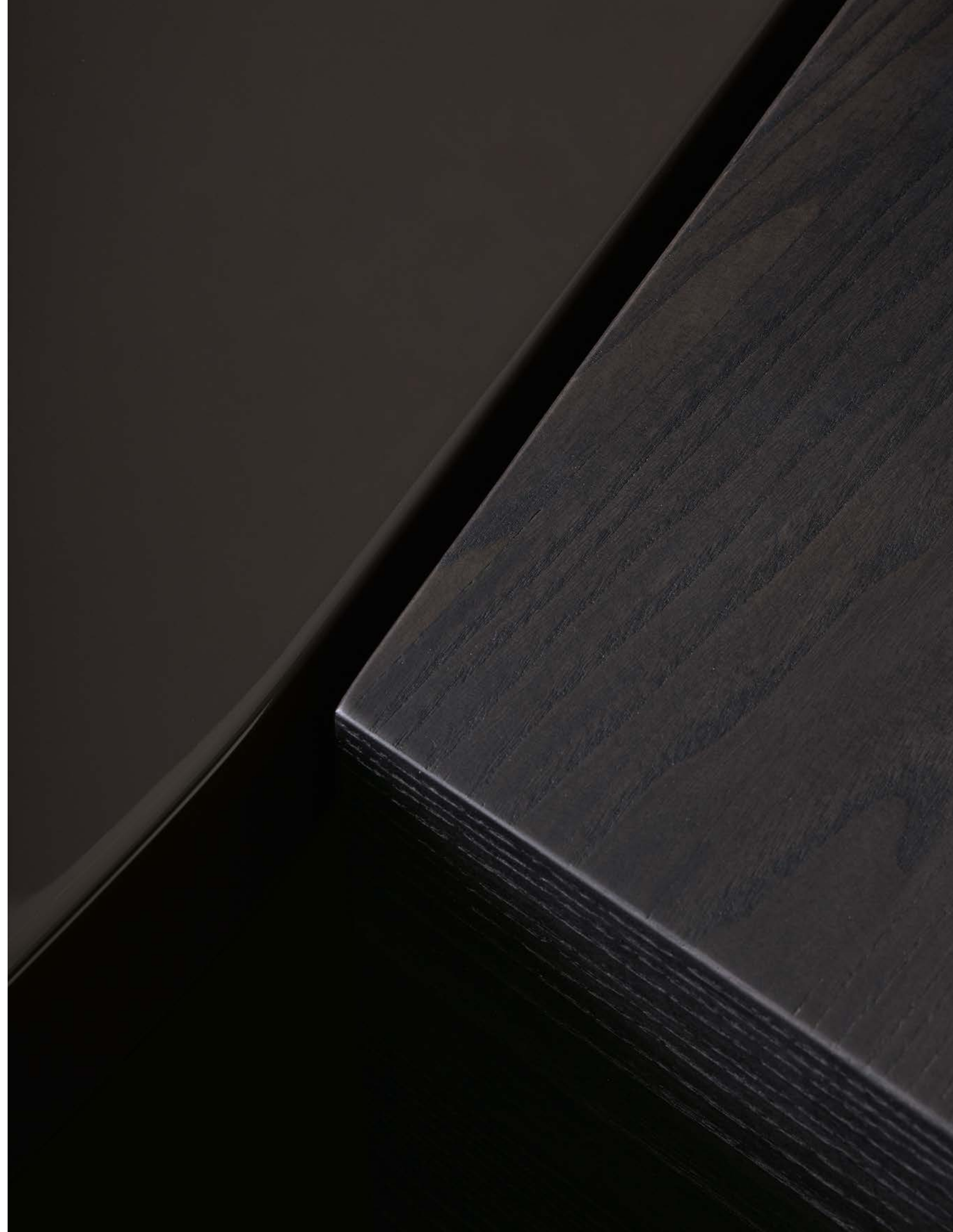



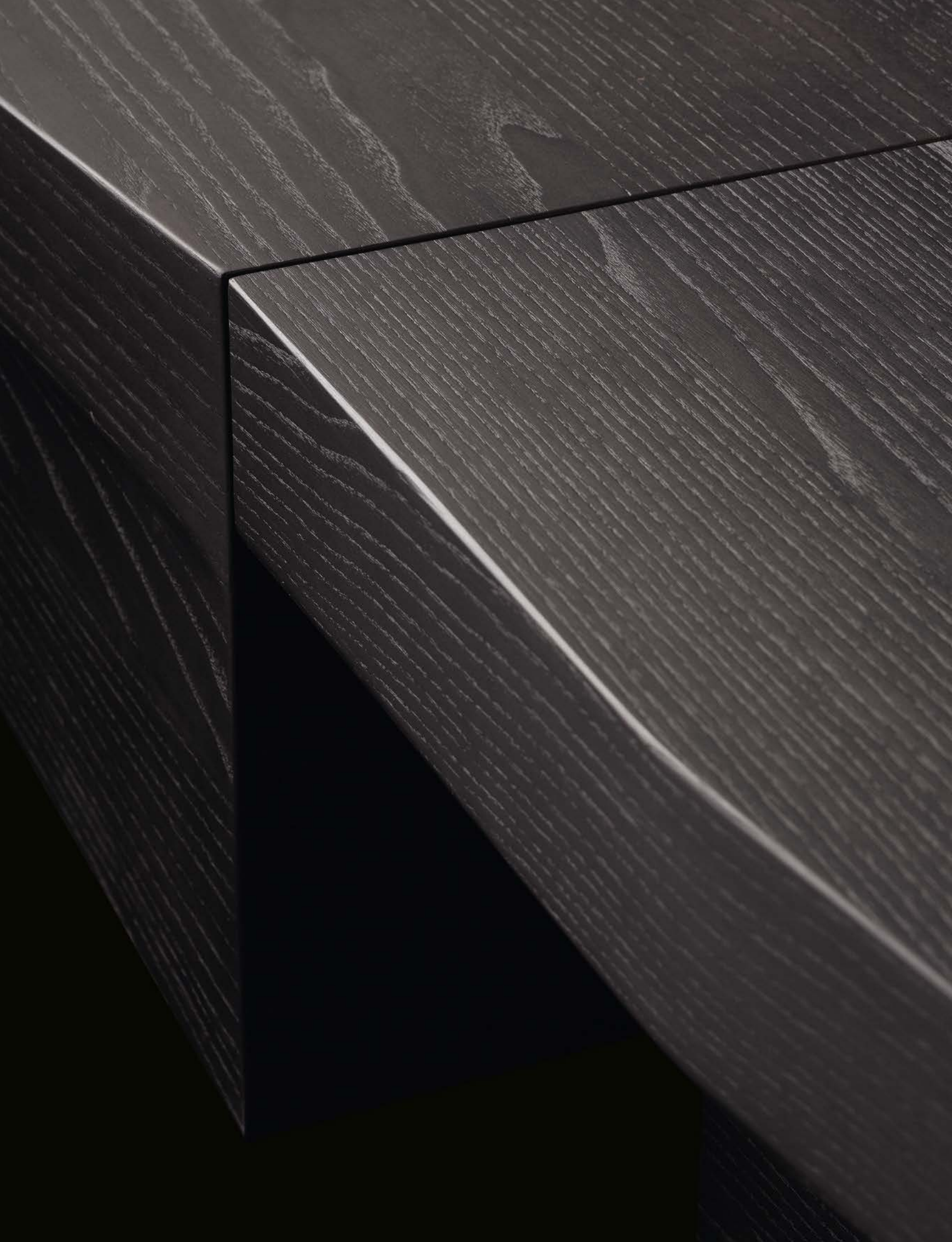

On this page: close up of the Joan coffee tables in black elm. On the previous pages: Joan coffee tables in black elm, moka glossy lacquer and glossy steel.



On this page: close up of the Joan coffee table in black elm. On the previous page: Joan coffee tables in black elm and glossy steel.



On this page: Joan coffee table in black elm, square version.



On this page: close up of the Joan coffee tables in glossy lacquer tundra. On the next page: Joan coffee tables in glossy lacquer tundra and glossy steel.



JOAN

Struttura e piano in pannello di fibra a media densità impiallacciato frassino tinto olmo

Structure and top in medium density fibre board veneered in black elm stained ash, glossy lacquered colours or glossy steel.

**Tavolini h 315**  
**Coffee tables h 12 1/2"**

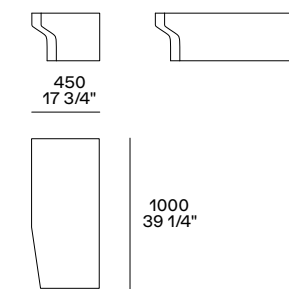
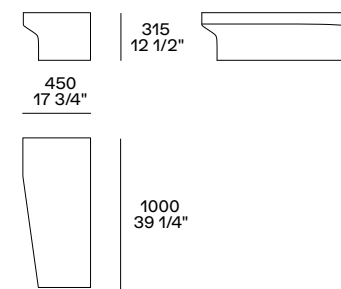
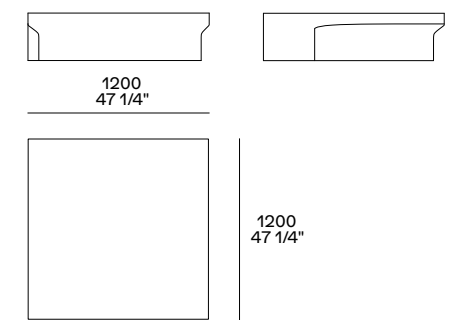
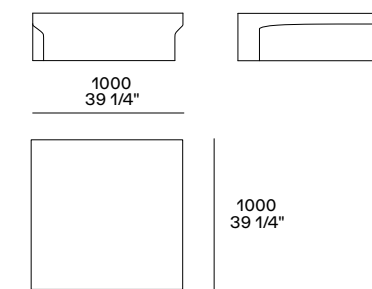
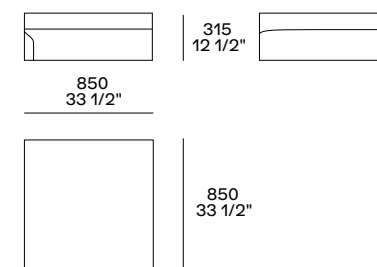

**Tavolino h 445**  
**Coffee table h 17 1/2"**

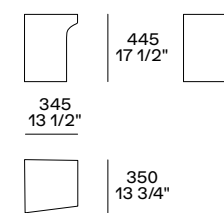



# OWEN COLLECTION

A cocooning design inspired by Mid-Century aesthetics. The Owen collection by Jean-Marie Massaud blends fluid, harmonious curves with a strong architectural foundation. In both the sofa and armchair, a wooden base supports plush, couture-inspired upholstery with organic contours. The standout

like a Mobius strip, seamlessly transitioning into the armrest. Striking a perfect balance between classics and contemporary, Owen redefines upholstered seating with a bold new design language.







On this, the previous and the next pages: Owen sofa with structure in solid wood stained black elm, removable cover in fabric Shire 02 avorio.



On this and on the next page: Owen armchair with structure in solid wood stained black elm, removable cover in leather Natural 04 fango.





On this and on the next page: Owen armchair with structure in solid wood stained black elm, removable cover in fabric Siro 01 bianco.





## OWEN

Struttura in massello finitura rovere spessart o tinto olmo nero.

in Polimex con imbottitura in poliuretano a quote differenziate. Cuscini schienale in tela cotone e fibra di poliestere con inserto in poliuretano.  
Prerivestimento in tela cotone.

Structure in solid wood finish spessart oak or stained black elm.

Seat with structure wood and wood-derivatives and multi-density polyurethane, backrest in Polimex with padding in multi-density polyurethane. Backrest cushions in cotton canvas and polyester fibre with polyurethane insert.  
Pre-cover in cotton canvas.  
Removable cover in fabric or leather.

### Divano Sofa

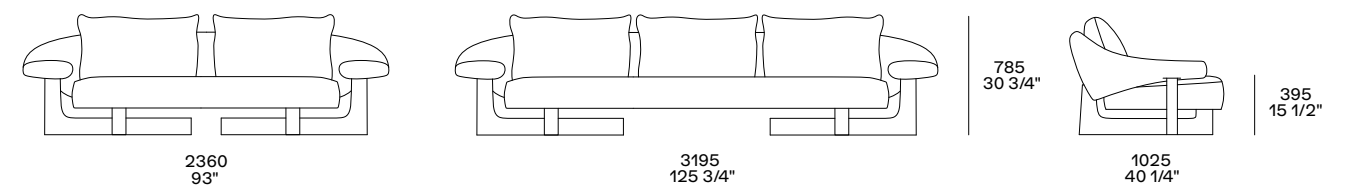

### Poltrona Armchair

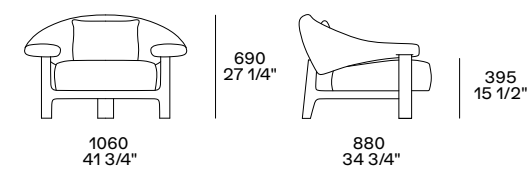

# LEOPOLD ARMCHAIR

Like the chair that inspired it, the Leopold Armchair features a sumptuous, enveloping cushion encased within a sleek wood-

balance of structure and softness is achieved by applying advanced industrial techniques to a design with an inherently handcrafted aesthetic, delivering exceptional comfort in both the seat and backrest.





LEOPOLD ARMCHAIR





On this page: close up of the Leopold armchair with structure in solid wood spessart oak finish, removable cover in fabric Siro 01 bianco. On the previous page: Leopold armchairs with structure in solid wood spessart oak finish, removable cover in fabric Shedir 06 oliva and in fabric Siro 01 bianco. On the introduction pages: details of the Leopold armchair with structure in solid wood spessart oak finish, removable cover in fabric Shedir 06 oliva.

On this and on the next page: Leopold armchair with structure in solid wood spessart oak finish, removable cover in leather Suede 02 corda.





## LEOPOLD

Struttura in massello finitura rovere spessart o tinto olmo nero.

Cuscino seduta in poliuretano a quote differenziate. Schienale in poliuretano

in poliuretano morbido.

Prerivestimento in tela cotone e piuma.

Structure in solid wood finish spessart oak or stained black elm.

Seat cushion in multi-density polyurethane. Backrest in single-density flexible moulded polyurethane and insert in soft polyurethane.

Pre-cover in cotton canvas and down. Removable cover in fabric or leather.

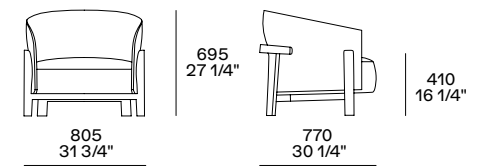

# ORBIS ARMCHAIR



The Orbis armchair by Emmanuel Gallina creates an intimate space within the living area. Characterized by its curved backrest and enveloping volumes, it is now reimagined with a new reading chairs.



On this and on the next pages: Orbis armchair in the new version with swivel base. Removable cover in velvet Persia 26 nero, base in glossy dark sheer metal.



On this and on the next page: Orbis armchair with removable cover in velvet Persia 26 nero, swivel base in glossy dark sheer metal.





## ORBIS

Struttura in metallo e poliuretano flessibile monoquota, seduta in poliuretano flessibile a quote differenziate, prerivestimento in tela cotone. Cuscino schienale in tela cotone e piuma.

Base girevole in fusione di alluminio verniciato opaco e lucido light sheer o dark sheer.

Structure in metal and flexible single-density polyurethane, seat in multi-density flexible polyurethane with pre-cover in cotton canvas. Backrest cushion in cotton canvas and down.

Swivel base in glossy and mat light sheer or dark sheer painted aluminium casting. Removable cover in fabric or leather.

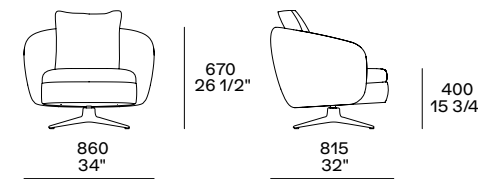

# ADRIEN COFFEE TABLE

The Adrien collection also includes coffee tables that highlight a timeless design, with sculptural legs that unify the different elements. Crafted for sophisticated living spaces, these tables come in generous proportions and can be grouped together for added impact.



On this and on the previous pages: Adrien coffee tables in black elm and glossy lacquer mosto, in the two available heights.





On this page: close up of the Adrien coffee table with top in mat marble nero marquina with polyester finish, structure in mat dark sheer metal.

On this and on the previous page: Adrien coffee table with top in mat marble nero marquina with polyester finish, structure in mat dark sheer metal.



On this and on the next page: Adrien coffee table in glossy lacquer mosto.



## ADRIEN

verniciato opaco e lucido light sheer  
o dark sheer.

Structure in solid wood stained black elm,  
glossy lacquered colours metal or  
mat and glossy light sheer or dark sheer  
painted metal.  
Top in glossy lacquered colours, black elm  
or mat and glossy marble (except travertino  
classico, travertino titanium and zecevo).

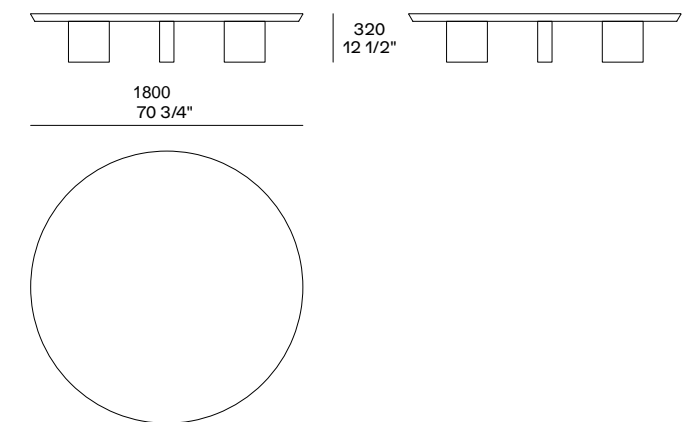
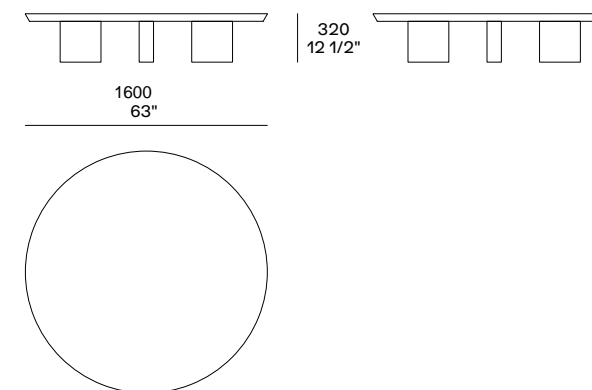
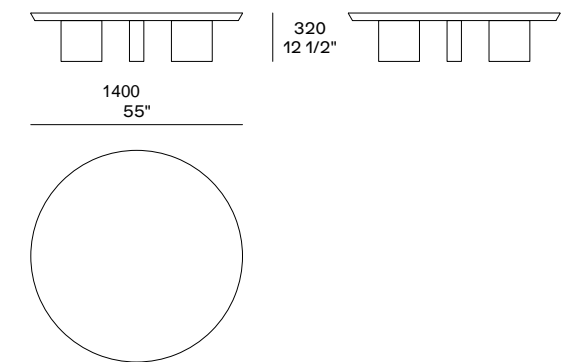
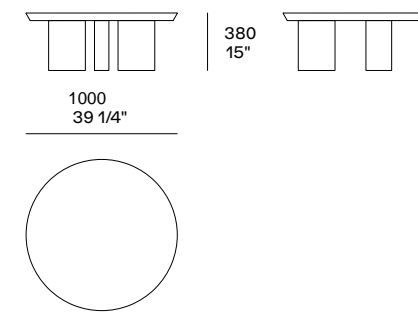

# TESS BOOKCASE



A light yet striking bookcase, Tess finds the perfect balance through an elegant interplay of asymmetry, thickness, and proportion. This piece by Jean-Marie Massaud is both a functional piece and a sculptural element, ideal for sophisticated interiors. Versatile in its design, Tess can be used as a free-standing unit, placed against a wall, positioned at the center of a room, or even behind a sofa as a stylish element. Carefully selected finishes add to its allure, ranging from sliding cast-glass panels to leather accessories, achieving a harmonious blend of industrial precision and artisanal craftsmanship.



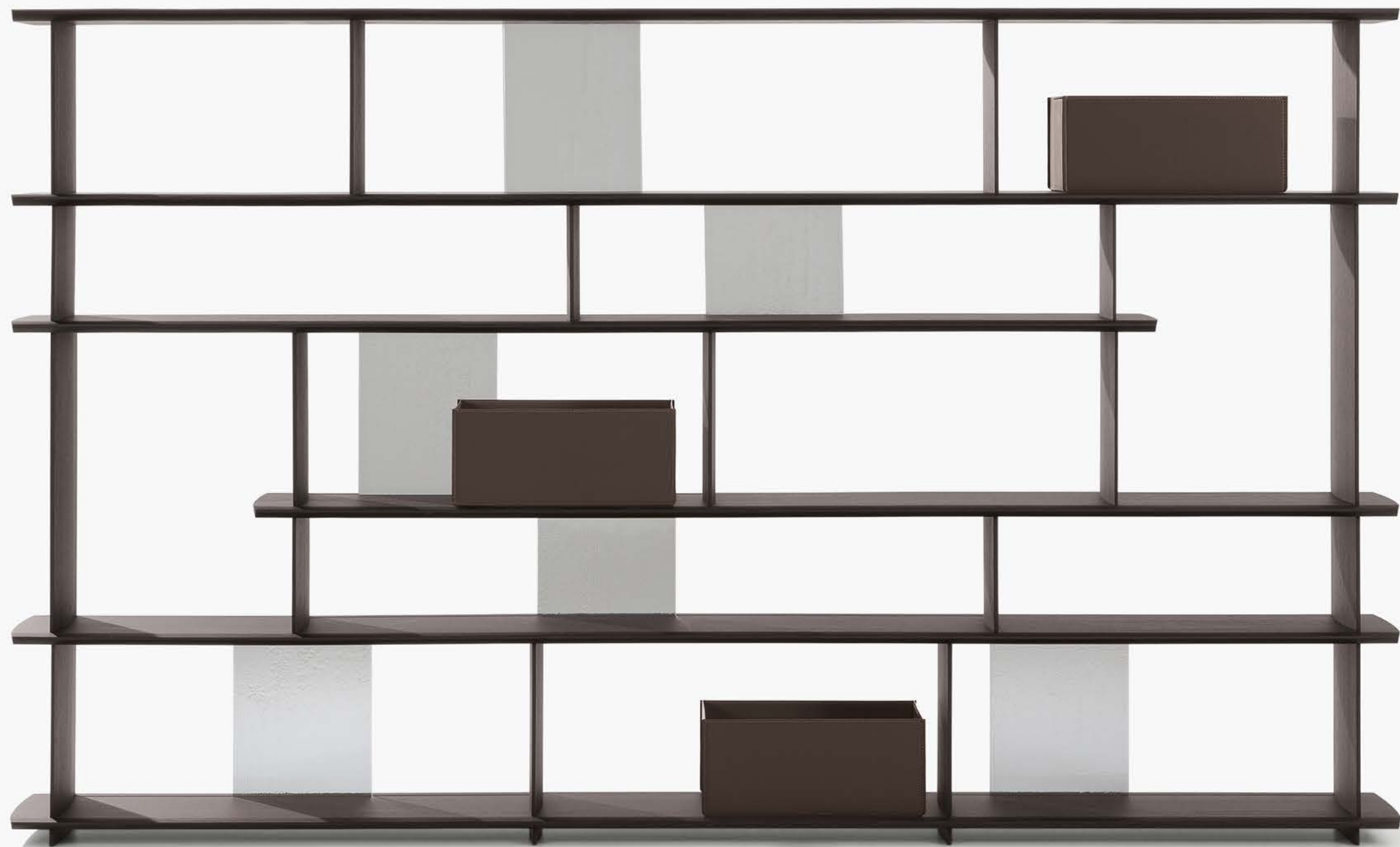



On this page: close up of the sliding back in fused glass rigato bronzo.  
On the previous pages: Tess bookcase in black elm, sliding backs in fused glass rigato fume, boxes in hide 19 caffè. On the next pages:  
Tess bookcase in black elm, sliding backs in fused glass rigato bronzo.



# TESS

Design Jean-Marie Massaud

Struttura in pannello di fibra a media densita

scorrevoli in vetrofusione rigato fume o bronzo. Scatole opzionali in cuoio colori.

Structure in medium density fibre board veneered in black elm with sliding backs in fused glass rigato fume or bronzo.

Optional boxes in hide in the available colours.

## Librerie h 715 Bookcases h 28 1/4"

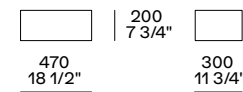
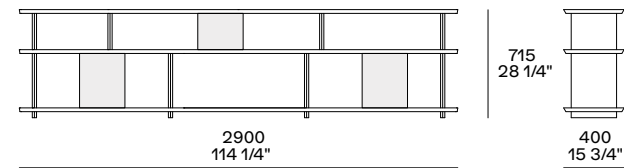
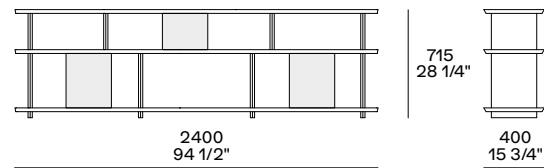
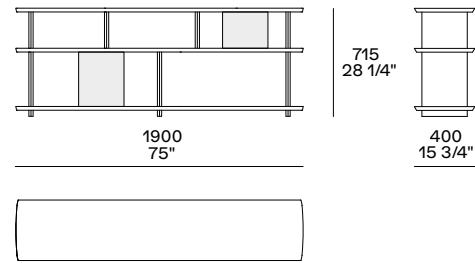

scatola opzionale  
optional box

## Librerie h 1100 Bookcases h 43 1/4"

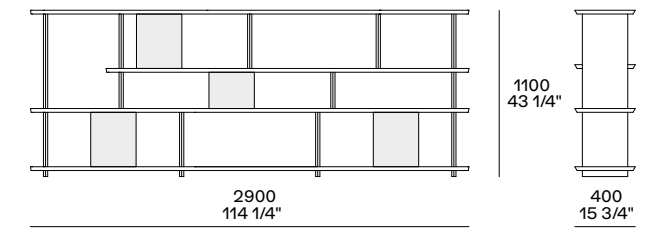
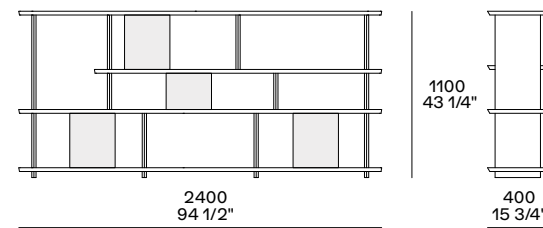
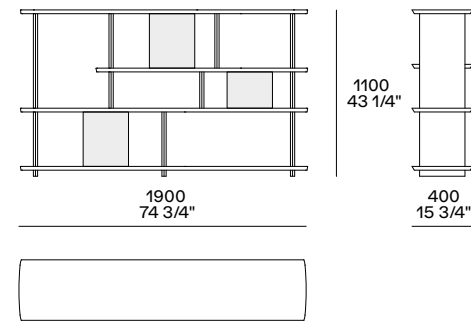

## Librerie h 1750 Bookcases h 69"

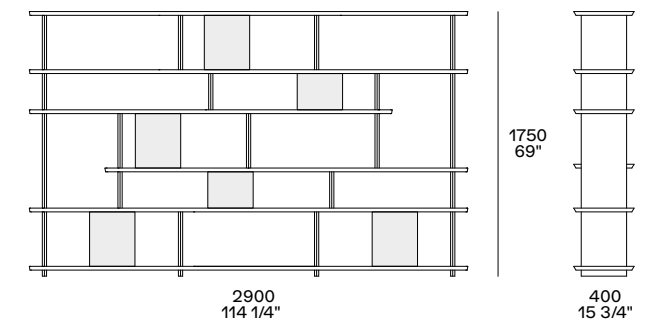
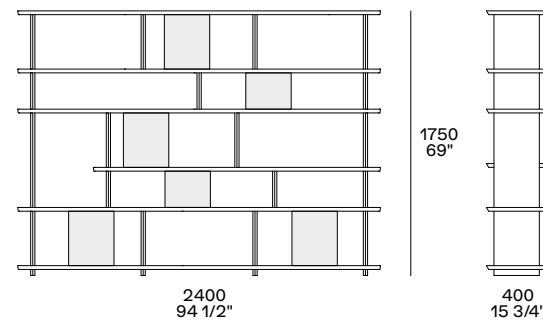
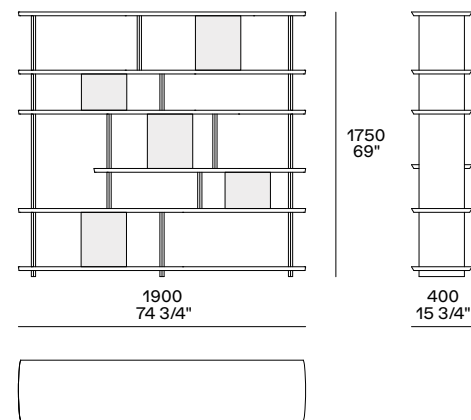

# ADRIEN HOME DESK

Plankfist's vision for the modern home office with a bold, char-

Available in various sizes, with options for an integrated side drawer unit, the Adrien desk features built-in cable management and is complemented by a luxurious leather desk pad.







On this page: close up of the top in black elm with optional desk pad in hide 02 nero. On the previous pages: Adrien desk with top in black elm, desk pad in hide 02 nero, swivel drawers in black elm and glossy dark sheer metal structure.



On this, on the previous and on the next page: Adrien desk in black elm with desk pad in hide 02 nero, in the versions with curved and straight top.





## ADRIEN

sheer o dark sheer.  
 Piano in olmo nero. Il piano e disponibile  
 anche con sottomano in cuoio colori.  
 Cassettiera orientabile in olmo nero,  
 opzionale.

Structure in solid wood stained black elm,  
 mat and glossy lacquered colours metal  
 or mat and glossy light sheer or dark sheer  
 painted metal.  
 Top in black elm. The top is available also  
 with desk pad in hide in the available  
 colours.  
 Optional swivel drawer unit in black elm.

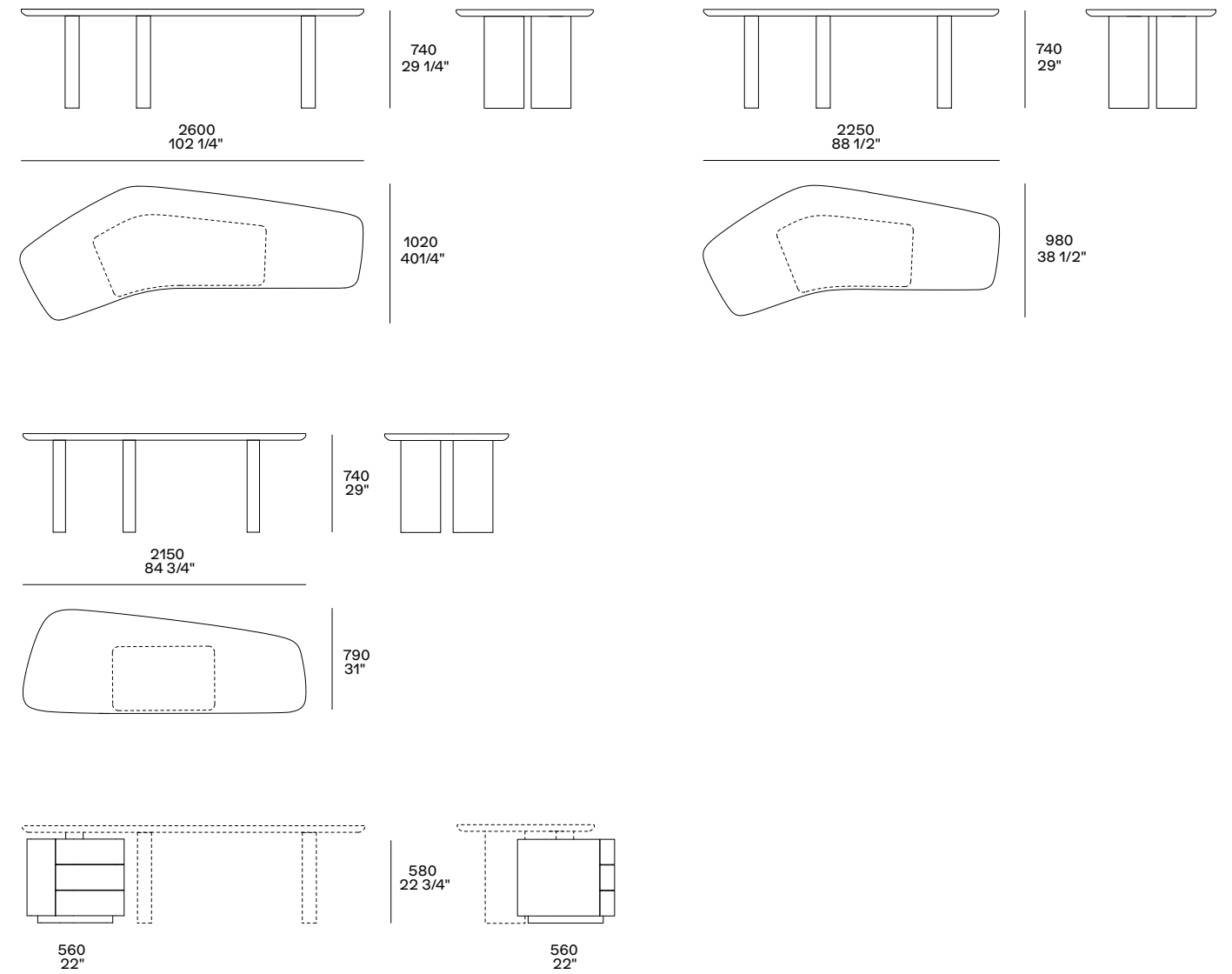

Cassettiera opzionale  
 Optional drawer unit



# ADRIEN TABLE

This table, with its commanding presence, is an icon of conviviality. Jean-Marie Massaud's Adrien table is reimagined in a larger size, available in both round and rectangular versions, making it the perfect centerpiece for grand spaces.







On this and on the next page: Adrien table with structure in glossy dark sheer metal, top in black elm and swivel central tray in mat marble nero marquina with polyester finish. On the previous pages: Adrien table with structure in mat light sheer metal, top in mat oyster white marble.



ADRIEN

sheer o dark sheer.  
girevole, opzionale in appoggio, in laccato zecevo).

Structure in solid wood stained black elm, mat and glossy lacquered colours metal or mat and glossy light sheer or dark sheer painted metal.  
Top in glossy lacquered colours, black elm or mat and glossy marble (except travertino classico, travertino titanium and zecevo).  
For the table 98 1/2" an optional spinning tray placed on top is available, finishes mat lacquered colours, walnut c, spessart oak, black elm or mat and glossy marble (except zecevo).

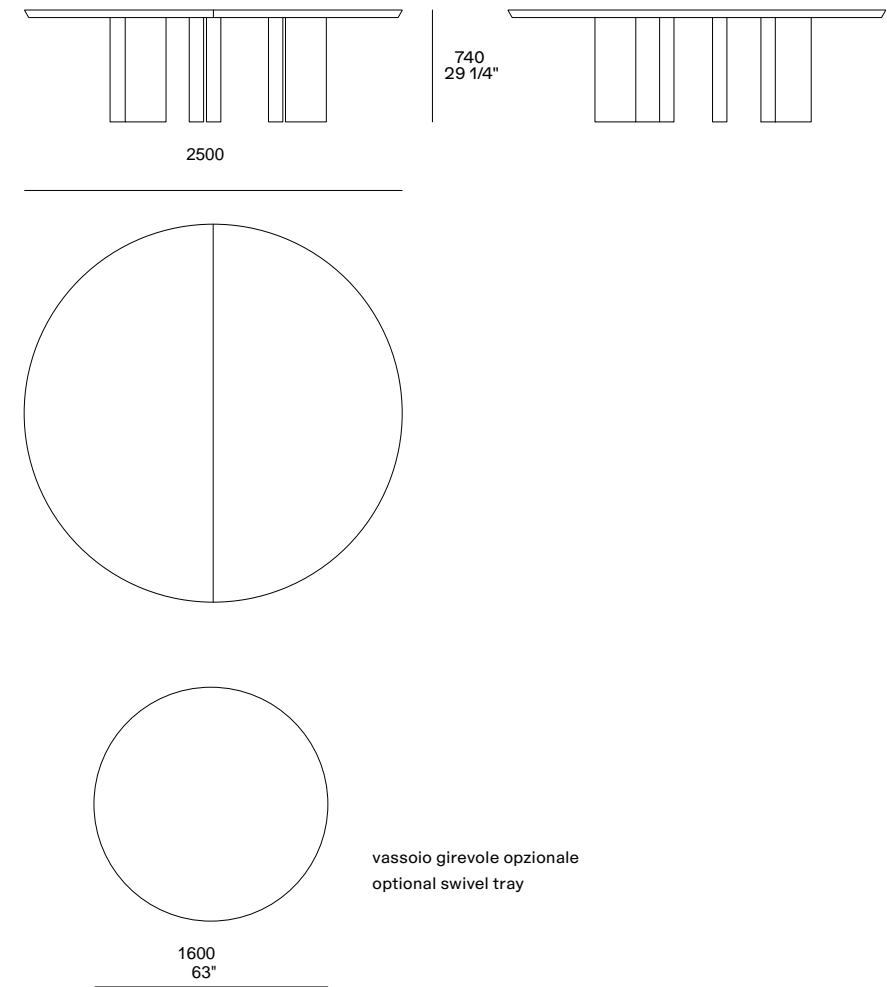
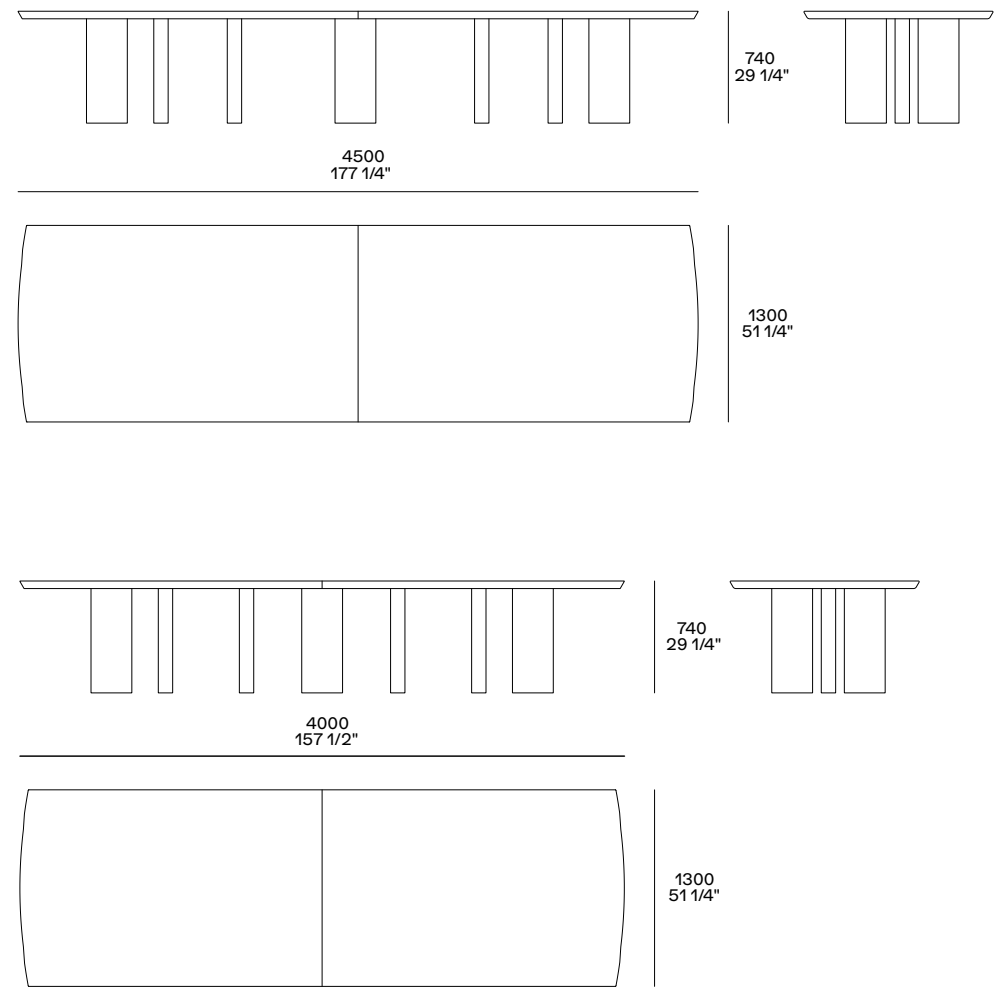

# NARA COLLECTION

a new lacquered finish. Inspired by the aesthetics of the Far East, its clean lines and sculptural volumes display a contemporary sensibility, with a glossy surface, enhancing the console, bench, and coffee table.



On this and on the next pages: Nara console in glossy lacquer borgogna.





On this page: close up of the Nara bench in glossy lacquer moka.

On this page: Nara bench in glossy lacquer moka.



On this and on the next page: Nara coffee tables in glossy lacquer torba, in the two available heights.





NARA

densita laccato lucido colori.

Structure and top in solid wood walnut c,  
stained black elm or medium density fibre  
board in glossy lacquered colours.

**Consolle  
Console**

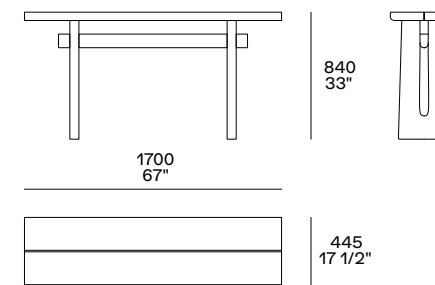

**Panca  
Bench**

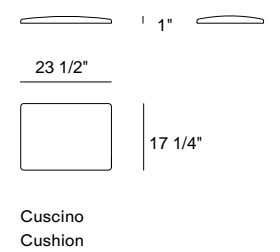
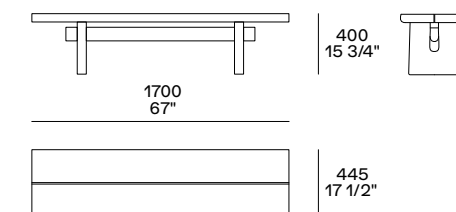
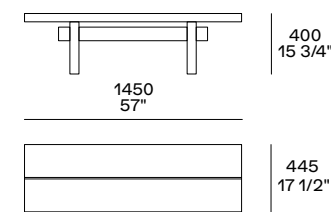

**Tavolino  
Coffee table**

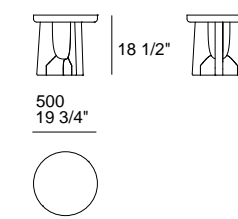
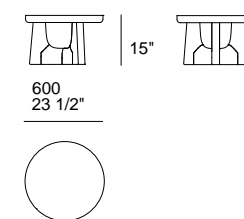

# ARTHUR LAMP



The Arthur lamp by studioutte is a highly technical piece where design is driven by pure functionality. A sleek take on the classic reading lamp that achieves absolute formal clarity through the simplicity of its lines. Light and unobtrusive, it's the perfect companion to sofas and armchairs, providing focused light where it's most needed.



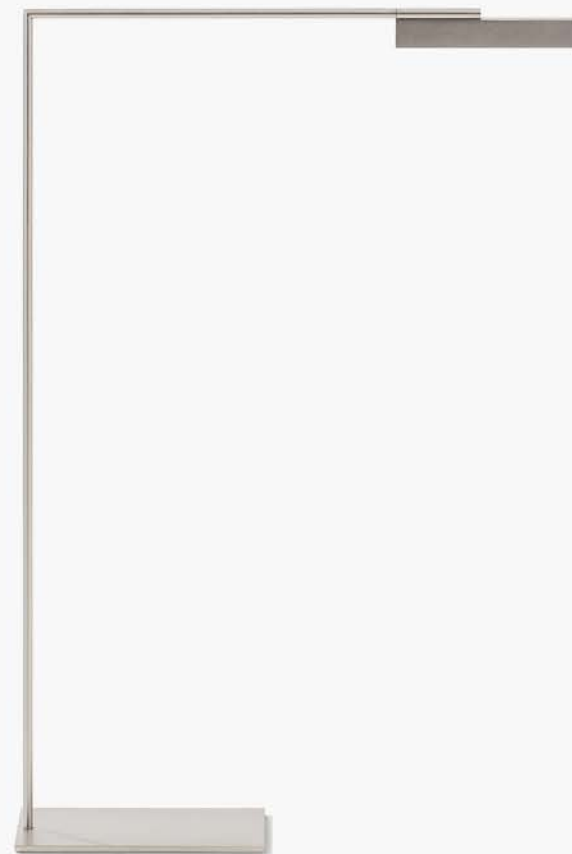

## ARTHUR

in feltro nella parte inferiore.

orientabile.

covered in felt on the underside.  
Dimmable led light 2700K.  
360 rotating structure and swivelling  
source unit.

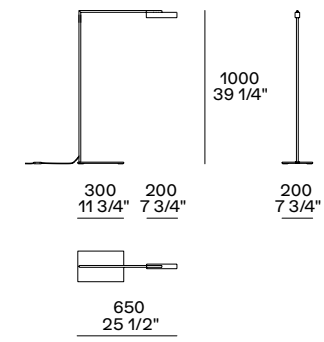

# HELGA LAMP

A lamp that embodies subdued elegance, designed for an ideal home where every detail reflects Plankfist's vision. Helga, by studioutte, reinterprets the classic lantern-expressive yet perfectly adapted to its surroundings. Available in both floor and table versions, it features a steel structure with a linen-covered light source that appears to be floating in space.

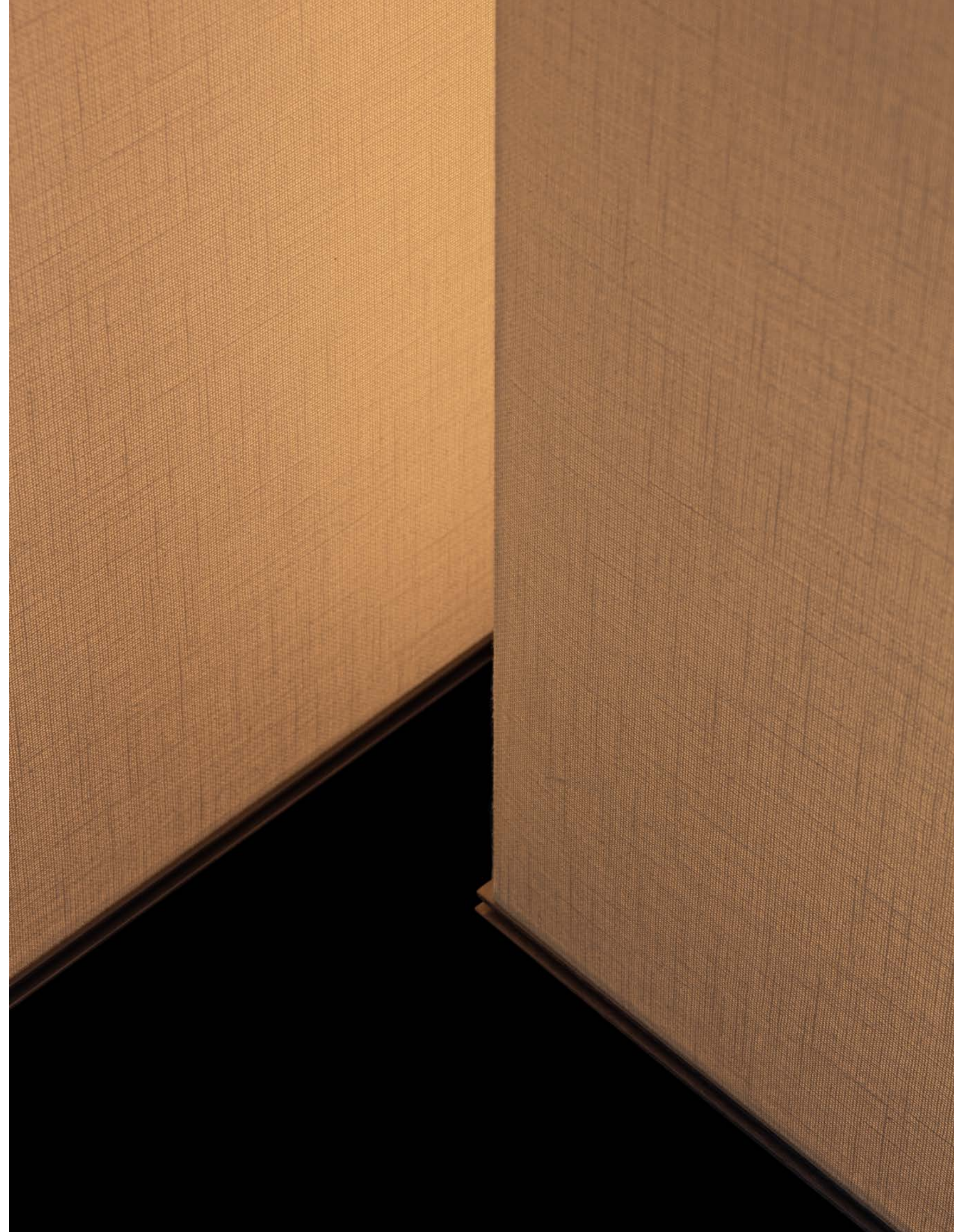



## HELGA

in feltro nella parte inferiore.  
Paralume in tessuto lino bianco accoppiato  
alla struttura in plexiglass trasparente.

Base opzionale in acciaio inox satinato.

covered in felt on the underside.  
Lampshade in white linen fabric coupled  
with a transparent plexiglass structure.  
Led light 2700K. Floor lamp with  
dimnable led light.  
Optional satin-finish stainless steel base.

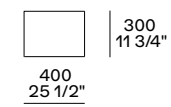
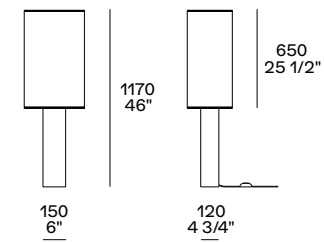

floor lamp

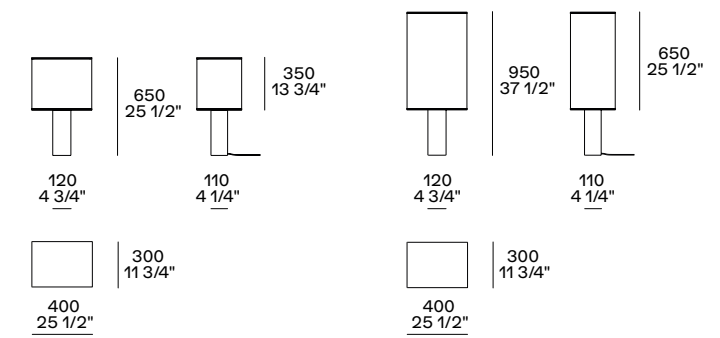
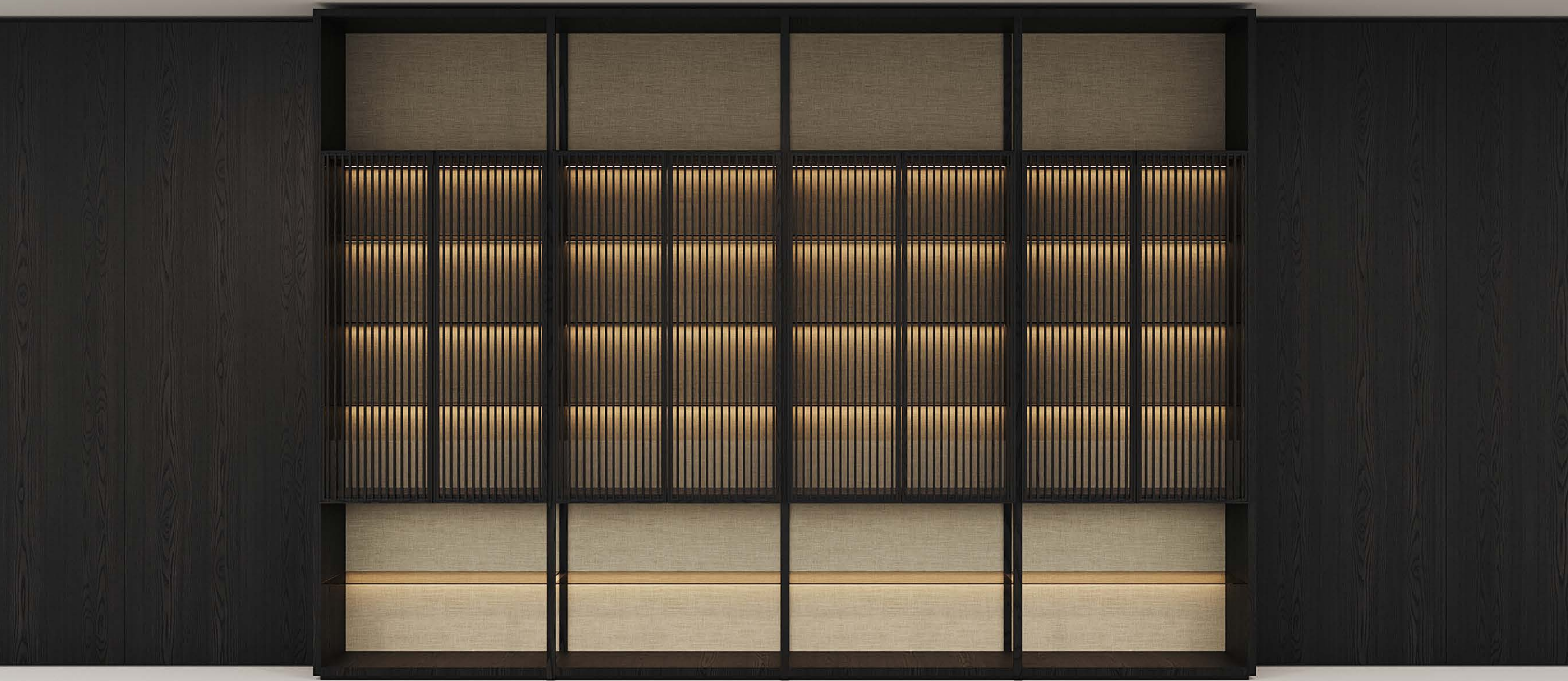

table lamps

# WALL SYSTEM

around a load-bearing bookcase structure. In keeping with the brand's latest design evolution, it has been reimagined with doors and accessories that accentuate its lightness- featuring vertical slatted doors, full-height framed side panels, the Stage frame without a base, and a new range of suspended storage units, including recessed-depth options, allowing for dynamic compositions of volumes and proportions.







On this page and on the next one: Wall System composition, structure in metal lacquer basalto, backs in fabric Mesh peltro and in black elm. Left and right, Ego Lite doors in glass rain ecru with frame and handle in black elm, fume glass shelves and moka glossy lacquered drawers. In the centre, portals in black elm, Block suspended units in glossy lacquer moka with flap doors. Integrated led light. On the previous pages: Wall System composition with structure and frame sides in black elm, backs in fabric Mesh peltro, Ego Lite Screen doors in fume glass and black elm, handle in mat moka, shelves in fume glass, integrated led light. On the sides of the Wall System composition, Surface wall panelling in black elm with mat ardesia profiles.



On this and on the next page: Wall System composition, structure and frame sides in black elm, backs in fabric Mesh moka. On the sides, Ego Day doors in transparent reflective glass with moka mat lacquered frame, shelves in fume glass, Status drawer units in glossy lacquer moka and mat noir saint laurent marble top. Central compartment with Stage backs in fabric Mesh moka. Integrated led light.

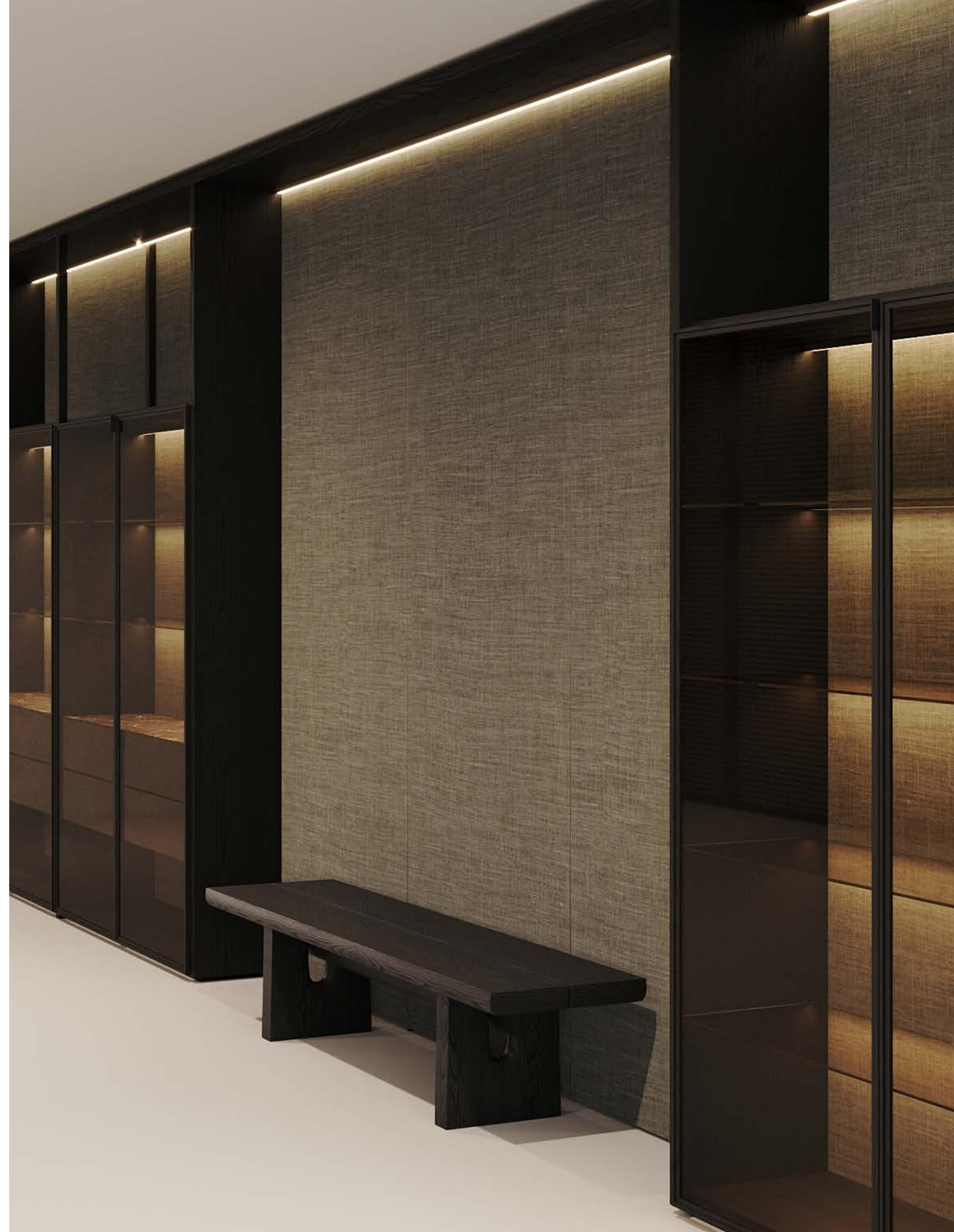



# LINK SYSTEM

The Link panel system, designed by Plankfist to divide and connect interior spaces, is now available in a new version featuring an insert, adding a light and contemporary aesthetic.

doppia. Pannelli e ante Link Side Grate in vetro trasparente extrachiaro in carbonio.

On this and on the next page: Link partition wall system, linear composition with fixed panels and two doors with double roto translating opening. Link Side Grate panels and doors in extra light transparent glass and in black elm, mat basalto frame and carbonio mat lacquered Side handle.





# SENZAFINE

A signature piece of Plankfist's night collection, evolving year after year. The latest updates to the Senzafine encompass a range of elements including doors, configurations, and finishes. A new door design introduces a fresh, almost three-dimensional aesthetic to the bedroom, enriching the tactile experience of the furniture. The new base-free columns create a lighter, more seamless integration into the architecture. Among the available configurations, the suspended storage units stand out, appearing to float within the frame.







On this and on the next page: Senzafine walk-in closet with structure in blond walnut melamine, mat champagne frame sides and backs in fabric Mesh ecru. Senzafine Swing leaf doors in tecnocover grain 10 miele with mat champagne profiles, Swing handle in tecnocover grain 10 miele and mat champagne. Senzafine Suite equipment, shelves in walnut blond melamine, extra light transparent glass and tecnocover grain 10 miele with walnut blond melamine frame, integrated led light. Hanging rails covered in tecnocover grain 10 miele and mat champagne. Chests of drawers with trays in walnut blond melamine, Mini handle in mat champagne and tecnocover grain 10 miele, lower drawers with fronts in transparent reflective glass; chests of drawers with drawer fronts in tecnocover grain 10 miele. Chests of drawers with tops in tecnocover grain 10 miele with walnut blond melamine frame. Senzafine Vanity with back in fabric Mesh ecru, sides and shelves in lite oak, integrated led light. Shelf in lite oak and tecnocover grain 10 miele and mat champagne. Mirror with frame in tecnocover grain 10 miele. On the previous pages: Senzafine Juta wardrobe with leaf doors in lite oak juta and mat champagne profiles, Swing handle in tecnocover grain 10 miele and mat champagne. Daytime units with sides in fabric Mesh ecru and mat champagne frame, back in fume mirror, integrated led light. Equipped units with extra light transparent glass shelves, open compartment and grid in lite oak with top in extra light transparent glass, upper drawer with front in transparent reflective glass and champagne silkscreen, lower drawers in lite oak with handles in tecnocover grain 10 miele and mat champagne.





# NEW INDOOR FABRICS

For Plankfist, the choice of fabrics plays a pivotal role in defining the character of each piece, adding depth through tactile and visual experiences. The 2025 collection embraces the curved, enveloping forms of the new designs, favouring velvety chenille textiles that follow their contours and offer a luxuriously soft touch. This year, two new fabrics make their debut, crafted using advanced weaving techniques that intertwine threads of varying thicknesses. The first stands out for its three-dimensional surface, playing with depth and texture, while the second, exceptionally soft, features delicate tonal variations, created by the subtle interplay of two complementary hues. Another new addition is the eco-friendly leather-look finish, crafted from corn-derived polyurethane. The colour palette, staying true to Plankfist's signature warm neutrals, is enriched with earthy tones of mustard and tobacco.

NUOVI TESSUTI INDOOR  
NEW INDOOR FABRICS

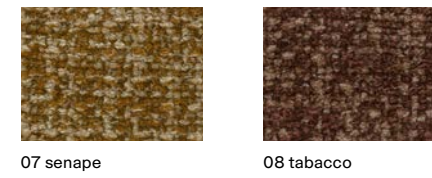
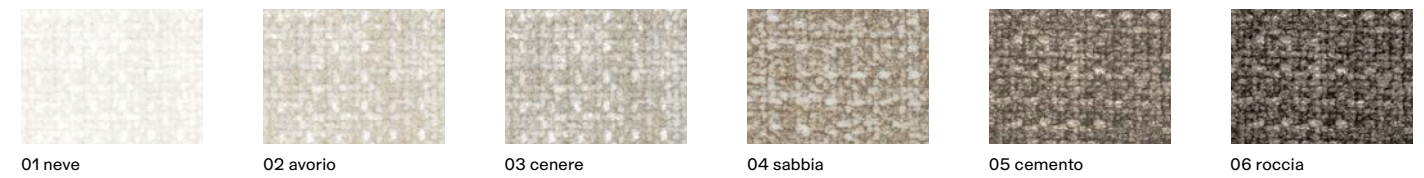

**Ecotech  
cat. y**

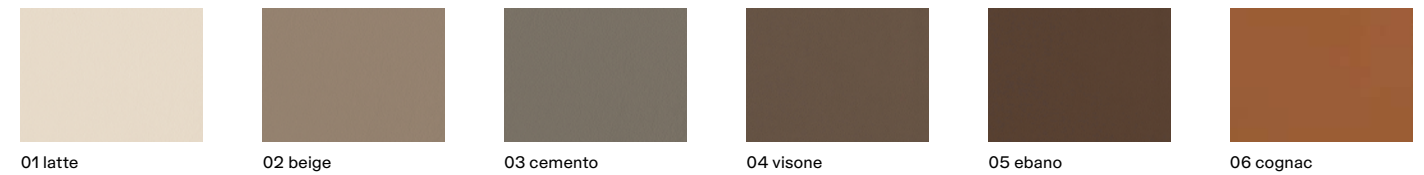

INDOOR PROPOSALS

COMPOSITION 01	200
COMPOSITION 02	202
COMPOSITION 03	204
COMPOSITION 04	206
COMPOSITION 05	208
COMPOSITION 06	210
COMPOSITION 07	212
COMPOSITION 08	214
COMPOSITION 09	216



**COMPOSITION 01**

lucido. Lampade Arthur in acciaio inox satinato, luce a led dimmerabile.  
Tappeto Shindo natural.

Joan sofa in removable velvet Persia 2002 bruciato, grosgrain border moro, mat brown nickel feet. Owen armchairs with structure in solid wood stained black elm, removable cover in fabric Siro 01 bianco. Joan coffee tables in black elm, glossy lacquer moka and glossy steel. Arthur lamps in satin-finish stainless steel, dimmable led light. Carpet Shindo natural.



**COMPOSITION 02**

laccato lucido moka e acciaio lucido. Lampade Arthur in acciaio inox

Joan sofa in removable fabric Olimpia 11 polvere, grosgrain border cenere, coffee table in black elm, mat brown nickel feet. Leopold armchairs with structure in solid wood stained black elm, removable cover in leather Natural 04 fango. Joan coffee tables in black elm, glossy lacquer moka and glossy steel. Arthur lamps in satin-finish stainless steel, dimmable led light. Carpet Trace ecru.



**COMPOSITION 03**

lucido. Lampada Helga in acciaio inox satinato e paralume in tessuto

Joan sofa in removable fabric Konik 01 bianco, grosgrain border burro, mat brown nickel feet. Owen armchairs with structure in solid wood stained black elm, removable cover in leather Natural 05 cognac. Joan coffee tables in black elm, glossy lacquer moka and glossy steel. Helga lamp in satin-finish stainless steel and lampshade in white linen fabric, dimmable led light. Carpet Shindo natural.



**COMPOSITION 04**

Suede 02 corda, piedini in metallo light sheer lucido. Tavolini Adrien in nero. Lampade Arthur in acciaio inox satinato, luce a led dimmerabile. Tappeto Frame ruggine.

Joan sofa in removable fabric Shedir 02 burro, grosgrain border burro, mat brown nickel feet. Orbis armchairs in removable leather Suede 02 corda, feet in glossy light sheer metal. Adrien coffee tables in black elm and with top in mat marble oyster white, structure in black elm. Arthur lamps in satin-finish stainless steel, dimmable led light. Carpet Frame ruggine.



**COMPOSITION 05**

inox satinato e paralume in tessuto lino bianco, luce a led dimmerabile.  
Tappeto Trace white.

Joan sofa in removable fabric Konik 03 senape, grosgrain border cioccolato, coffee table in black elm, mat brown nickel feet. Owen armchair with structure in solid wood stained black elm, removable cover in leather Nabuk 01 latte. Adrien coffee tables in glossy lacquer moka and with top in mat marble nero marquina with polyester finish, structure in mat dark sheer metal. Helga lamp in satin-finish stainless steel and lampshade in white linen fabric, dimmable led light. Carpet Trace white.



**COMPOSITION 06**

moka e acciaio lucido. Lampade Arthur in acciaio inox satinato, luce a led dimmerabile. Tappeto Shindo grey.

Joan sofa in removable fabric Shire 03 cenere, grosgrain border burro, cushions in fabric Konik 01 bianco, mat brown nickel feet. Orbis armchairs in removable velvet Persia 26 nero, feet in glossy dark sheer metal. Joan coffee tables in black elm, glossy lacquer moka and glossy steel. Arthur lamps in satin-finish stainless steel, dimmable led light. Carpet Shindo grey.



**COMPOSITION 07**

in acciaio inox satinato, luce a led dimmerabile. Tappeto Trace white.

Joan sofa in removable velvet Persia 1401 oliva, grosgrain border oliva, coffee table in black elm, mat brown nickel feet. Owen armchairs with structure in solid wood stained black elm, removable cover in leather Silk 01 crema. Adrien coffee tables in glossy lacquer canapa and with top in mat marble calacatta oro, structure in black elm. Arthur lamps in satin-finish stainless steel, dimmable led light. Carpet Trace white.



**COMPOSITION 08**

ra gros-grain acciaio, piedini in brown nickel opaco. Tavolini Joan in  
tinto olmo nero. Lampade Helga in acciaio inox satinato e paralume in

Joan sofa in removable leather Nabuk 01 latte, mat brown nickel feet.  
Joan armchairs in removable fabric Konik 06 grafite, grosgrain border  
acciaio, mat brown nickel feet. Joan coffee tables in glossy lacquer  
mosto and glossy steel. Ube stools in solid wood stained black elm.  
Helga lamps in satin-finish stainless steel and lampshade in white linen  
fabric, dimmable led light. Carpet Trace white.



**COMPOSITION 09**

Lampade Helga in acciaio inox satinato e paralume in tessuto lino bian-

Joan sofa in removable fabric Konik 06 grafite, grosgrain border acciaio, mat brown nickel feet. Leopold armchairs with structure in solid wood stained black elm, removable cover in leather Nabuk 10 oliva. Adrien coffee tables in glossy lacquer tundra and with top in mat marble verde lepanto, structure in solid wood stained black elm. Helga lamps in satin-finish stainless steel and lampshade in white linen fabric, dimmable led light. Carpet Plain tortora.



FURNITURE INDOOR  
INDOOR FINISHINGS

**Mat and glossy lacquer**



**Mat lacquer**



**Laccato antigraffio  
Scratchproof lacquer**



**Essenza  
Wood**



**Essenza Print  
Wood Print**

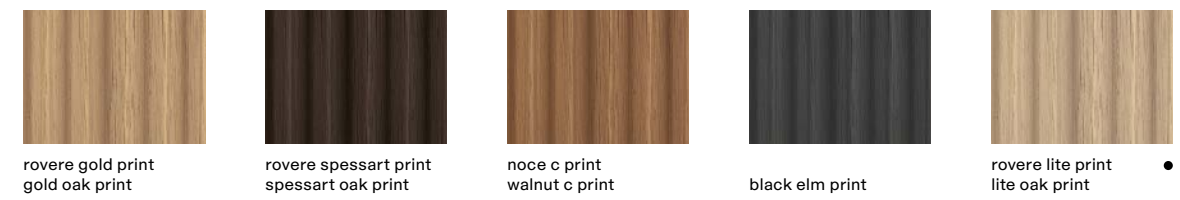

**Essenza Juta \*  
Wood Juta**



armadio Senzafine  
only for Juta door  
Senzafine wardrobe

**Laccato metallico  
Metallic lacquer**



**Acciaio  
Steel**

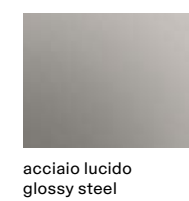

● news

FURNITURE INDOOR  
INDOOR FINISHINGS

**Cuoio  
Hide**

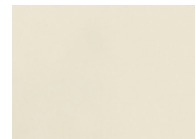

09 burro



29 tortora



08 fango

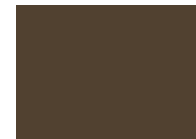

19 caffè



26 invecchiato



07 castagna

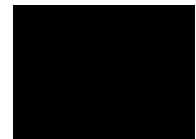

02 nero

**Tecnocover Grain  
Tecnocover Grain**

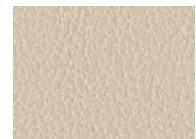

05 latte



01 elefante



02 moro



06 nocciola



07 roccia



08 cognac

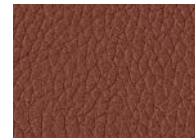

09 terracotta



10 miele

**Tessuto  
Fabric**



lino chiaro



lino ecru



lino bruciato



lino scuro



mesh ecru



mesh peltro



mesh moka



mesh bronzo



mesh ruggine

**Inalco MDi  
Inalco MDi**

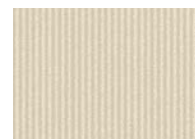

rigato chiaro



rigato scuro

**Corda intrecciata  
Braided rope**

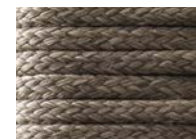

cenere

● news

TECHNICAL DATA

**Mat marble**



bianco carrara



calacatta oro



oyster white



grigio stardust



verde lepanto

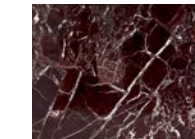

rosso lepanto



zecevo



travertino classico  
poro chiuso - closed pore



travertino titanium  
poro chiuso - closed pore



sahara noir  
finitura poliester  
polyester finish



nero marquina  
finitura poliester  
polyester finish

**Marmo lucido  
Glossy marble**



bianco carrara



calacatta oro



oyster white



grigio stardust

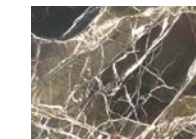

verde lepanto

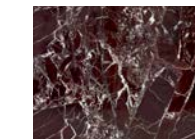

rosso lepanto

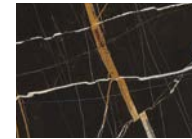

sahara noir  
finitura poliester  
polyester finish

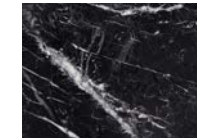

nero marquina  
finitura poliester  
polyester finish



noir saint laurent

**Onice  
Onyx**



ambra  
amber



lapislazzulo blu  
blue lapis lazuli

**Semiprezioso  
Semiprecious stone**

**Pietra spatolata  
Spatula-finish stone**

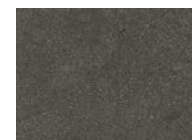

ebano  
ebony

NEWS 2025

223

FURNITURE INDOOR  
INDOOR FINISHINGS

**Tessuti**  
**Fabrics**



chios cat. b  
13 colori - colours



eraclea cat. b  
12 colori - colours

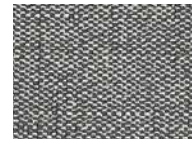

lima cat. c  
11 colori - colours



antea cat. d  
13 colori - colours



irati cat. d  
11 colori - colours



itaca cat. d  
10 colori - colours



kiala cat. d  
13 colori - colours

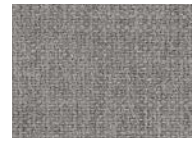

kushiro cat. d  
13 colori - colours



micene cat. d  
9 colori - colours

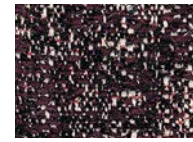

olimpia cat. d  
14 colori - colours



rabat cat. d  
10 colori - colours



sendai cat. d  
5 colori - colours



sparta cat. d  
12 colori - colours

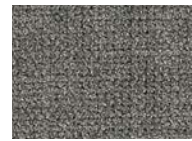

yukon cat. d  
20 colori - colours



9 colori - colours



12 colori - colours



12 colori - colours



13 colori - colours



10 colori - colours



10 colori - colours



12 colori - colours



11 colori - colours



8 colori - colours



9 colori - colours

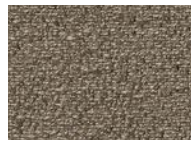

7 colori - colours



11 colori - colours



10 colori - colours



10 colori - colours



16 colori - colours



14 colori - colours



6 colori - colours



8 colori - colours

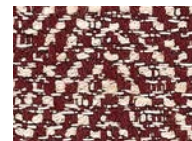

12 colori - colours

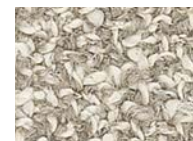

brest cat. g  
10 colori - colours

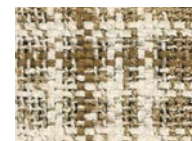

dundee cat. g  
6 colori - colours



glasgow cat. g  
6 colori - colours



hamal cat. g  
4 colori - colours



lero cat. g  
2 colori - colours



nancy cat. g  
6 colori - colours

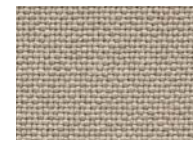

norwich cat. g  
8 colori - colours



sheffield cat. g  
9 colori - colours



siro cat. g  
4 colori - colours

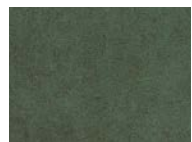

tebe cat. g  
11 colori - colours



janaky cat. m  
6 colori - colours

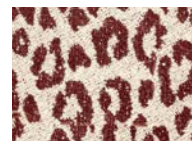

mintaka cat. m  
3 colori - colours



yushan cat. m  
6 colori - colours

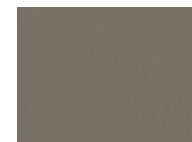

ecotech cat. y  
7 colori - colours

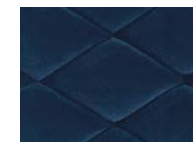

gibson cat. z  
6 colori - colours

● news

**Pelle**  
**Leather**



spring cat. p  
13 colori - colours



colors cat. s  
25 colori - colours

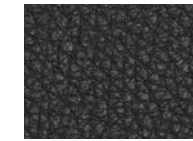

silk cat. s  
13 colori - colours



silk intrecciata cat. s  
woven leather silk  
13 colori - colours

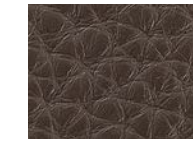

deep cat. x  
10 colori - colours



special cat. x  
21 colori - colours



suede cat. x  
7 colori - colours



nabuk cat. y  
10 colori - colours



nabuk intrecciata cat. y  
woven leather nabuk  
10 colori - colours



natural cat. y  
10 colori - colours



soft cat. y  
14 colori - colours

**Pelliccia Cashmere**  
**Cashmere fur**



bianco

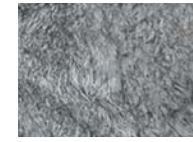

grigio



nero

**Pelle Hairy**  
**Hairy leather**



bianco/nero



cappuccino



nero

**Tecnocover Pixel**  
**Pixel tecnocover**

FINITURE INDOOR  
INDOOR FINISHINGS

**Bordura gros-grain - filati**  
**Grosgrain border - yarns**



burro perla nuvola cenere sahara terra



oliva amaranto tempesta navy acciaio nero

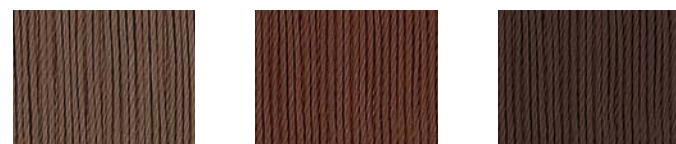

cioccolato • caramel • moro •

**Provence coordinati letto**  
**Bed linen Provence**



01 bianco 02 panna 08 polvere 04 tortora 06 roccia 07 grafite



03 ghiaccio

**Coperta Linus**  
**Linus blanket**

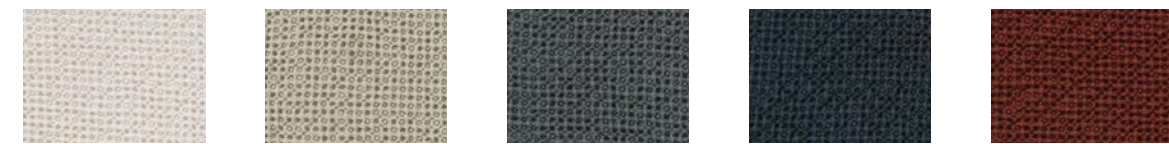

latte corda grafite notte granata

**Lampade**  
**Lamps**



acciaio inox satinato • lino bianco •  
satin stainless steel white linen

FINITURE INDOOR  
INDOOR FINISHINGS

**Vetro  
Glass**



1000 trasparente  
transparent



2000 trasparente  
extrachiaro-transparent  
extralight



3051 bronzato  
bronzed



3050 fume



rain bianco



rain ecru

**Vetro riflettente  
Reflecting glass**



5000 trasparente  
transparent



5010 blu



5051 bronzato  
bronzed



5059 fume

**Vetro acidato  
Etched glass**



5380 acciaio



5323 bronzo



5325 titanio

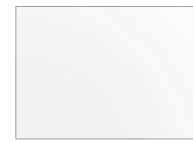

**Specchio  
Mirror**

4000 bianco  
white



4051 bronzato  
bronzed



4050 fume

**Mat and glossy glass**



bianco  
extrachiaro - extralight  
2301 satinato - mat  
2201 lucido - glossy

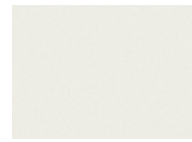

ghiaccio  
2373 satinato - mat  
2273 lucido - glossy



canapa  
1335 satinato - mat  
1235 lucido - glossy



arena  
1364 satinato - mat  
1264 lucido - glossy



nero  
1303 satinato - mat  
1203 lucido - glossy

**Vetro stratificato  
Stratified glass**

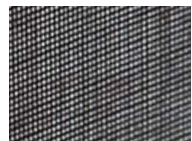

2C01 lino carbone  
linen carbone

**Vetrofusione  
Fused glass**



bronzo  
bronze



fume  
fume

**Vetrofusione rigato  
Fused glass rigato**



bronzo  
bronze

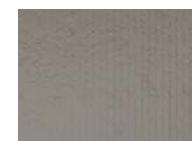

fume

**Nobilitato  
Melamine**



olmo  
elm



noce blond  
blond walnut

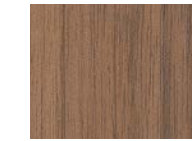

noce brown  
brown walnut

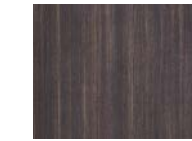

rovere spessart  
spessart oak



rovere cenere  
cenere oak

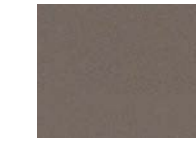

basalto



canvas tortora



club 01 bianco



silk canapa



silk grey

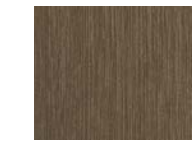

silk bronzo

**Melamine drawers structure**



basalto

**Parti metalliche  
Metal parts**



brown nickel opaco  
mat brown nickel



brown nickel lucido  
glossy brown nickel



brown nickel satinato  
brushed brown nickel



champagne opaco  
mat champagne



champagne satinato  
brushed champagne



ardesia opaco  
mat ardesia



cromo satinato  
brushed chrome



cromo nero  
black chrome

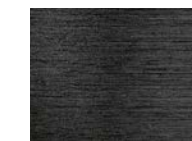

cromo nero satinato  
brushed black chrome



bronzato  
bronzed



brunito opaco  
mat brunito

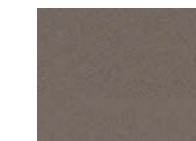

basalto opaco  
mat basalto



spatolato ferro  
spatula-finish ferro

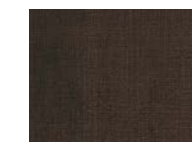

spatolato bronzo  
spatula-finish bronzo



oro lucido  
glossy gold



alluminio brill  
aluminium brill

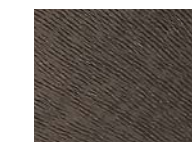

bronzo anticato  
antique bronze



light sheer opaco  
mat light sheer



light sheer lucido  
glossy light sheer



dark sheer opaco  
mat dark sheer



dark sheer lucido  
glossy dark sheer



oxid opaco  
mat oxid

● news

# OUTDOOR COLLECTION

ration to a nautical aesthetic. Emmanuel Gallina, the designer behind most of the pieces, draws from the elegance of sailing boats for the modular Lagoon system and the Ponte armchairs and sofas. The elegant and decorative Reef and Atoll tables evoke the smooth, water-worn forms of coastal rocks. The same maritime aesthetic defines the Marina chair, designed to complement the Henry table, now reimagined for outdoor settings. The collection is rounded out by Soo Chan's Soori Day armchair and Soori coffee tables.

## OUTDOOR COLLECTION

LAGOON SOFA	234
PONTE COLLECTION	247
REEF COFFEE TABLE	261
ATOLL COFFEE TABLE	271
DAMA COFFEE TABLE	277
HENRY TABLE	283
MARINA CHAIR	297
SOORI DAY ARMCHAIR	307
SOORI COFFEE TABLE	317
NEW OUTDOOR FABRICS	327
OUTDOOR PROPOSALS	331
TECHINICAL DATA	345

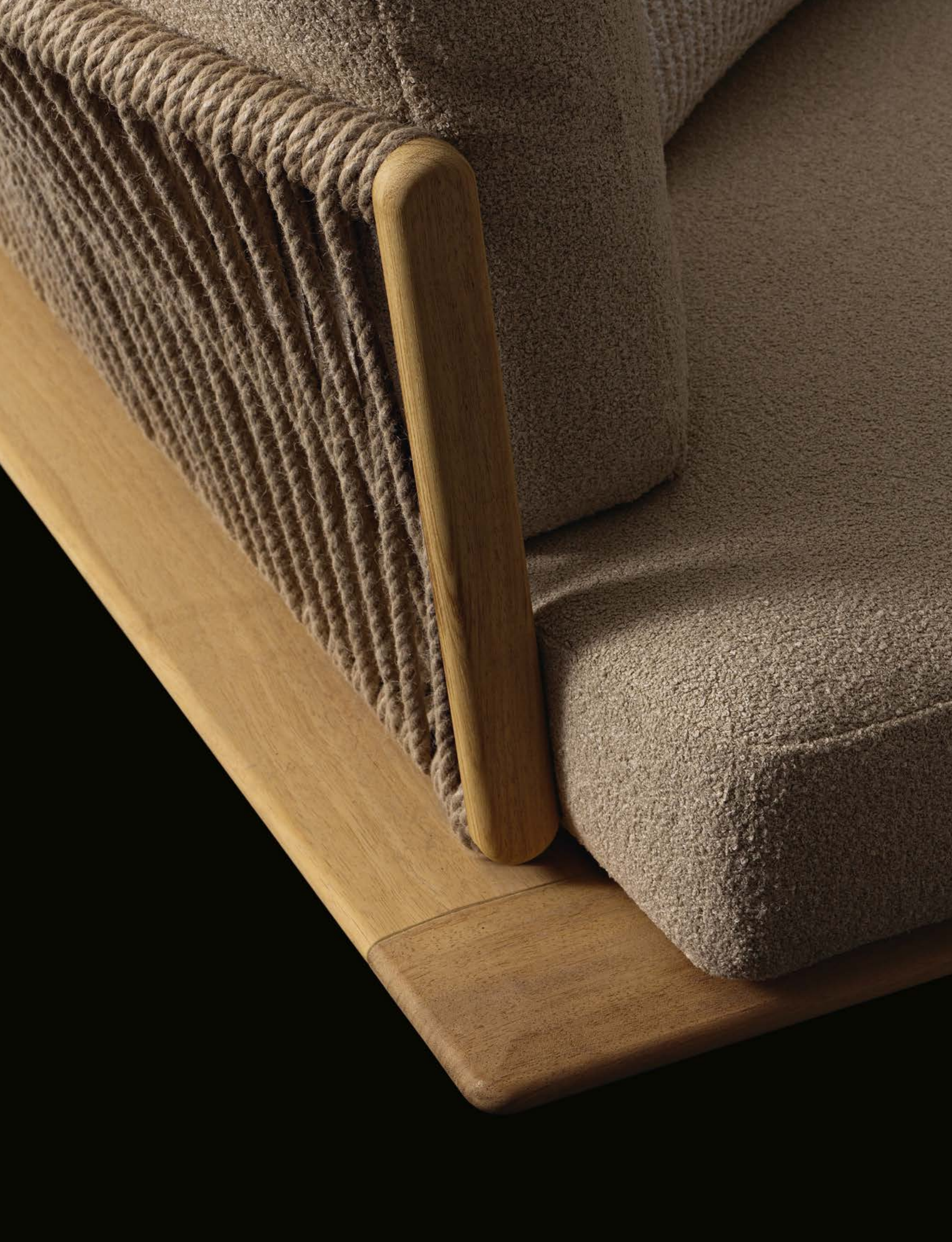

# LAGOON SOFA

The Lagoon modular system, designed by Emmanuel Gallina, draws inspiration from sailing, embracing the elegance of sailboats. Its slatted teak base reflects classic nautical craftsmanship, while the rope-woven backrest, inspired by boat

both fixed and movable-boosts the sofa's comfort, striking the perfect balance between support and relaxation for outdoor living.





tessuto Mojave 01 corda.

On the previous page Lagoon sofa corner composition, on the next page Lagoon linear sofa, both with base in solid teak and backrest in twisted rope naturale, feet in embossed painted oxid. Removable cover in fabric Nashi 05 corda, cushions in fabric Mojave 01 corda.



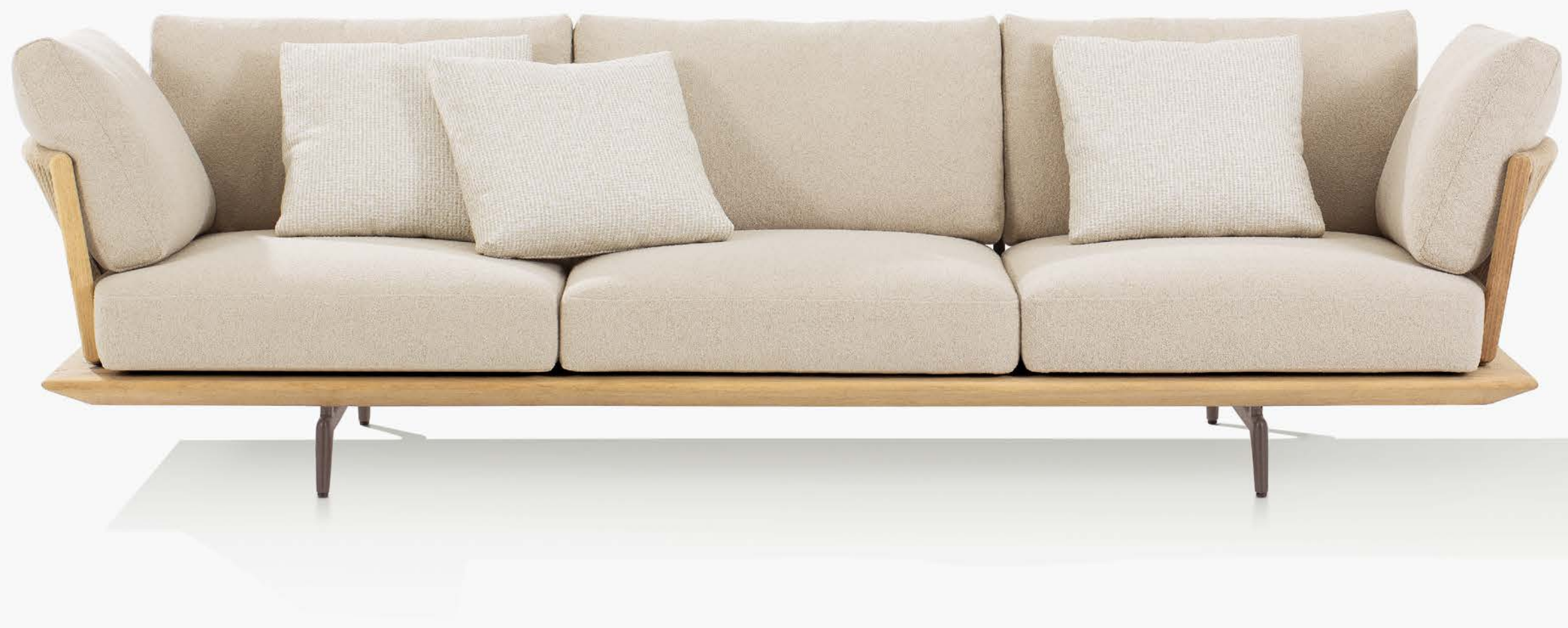

# LAGOON

inox verniciato e rivestito in corda nei colori mattone e testa di moro o in corda ritorta

Cuscino seduta in poliester riciclato PET con inserto in poliuretano espanso a quote differenziate. Cuscino schienale in poliester riciclato PET con inserto in poliuretano. Prerivestimento in fibra di poliester. Rivestimento sfoderabile in tessuto. Tavolino centrostanza in massello di teak, piedini in fusione di alluminio verniciato goffrato nel colore oxid. Piano in appoggio opzionale in gres con vetro colato nei colori

structure painted and covered in rope in the colours mattone and testa di moro or in twisted rope in the colour naturale. Seat in recycled PET polyester with multi-density polyurethane foam insert. Backrest cushion in recycled PET polyester with polyurethane insert. Pre-cover in polyester fiber. Removable cover in fabric. Freestanding coffee table in solid teak, feet in embossed painted aluminum casting in the colour oxid. Optional placed-on top in gres with cast glass in the colours crema, menta and terracotta.

## Divano Sofa

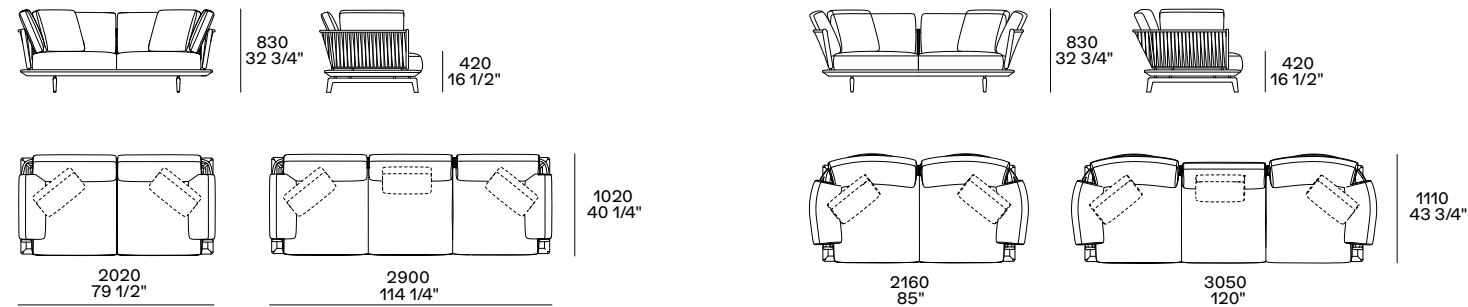

## Terminale sx-dx Lt-rt end unit

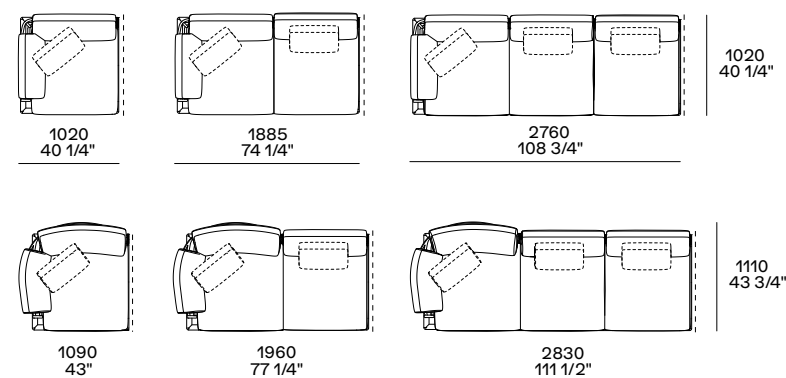

## Terminale penisola sx-dx Lt-rt peninsula end unit

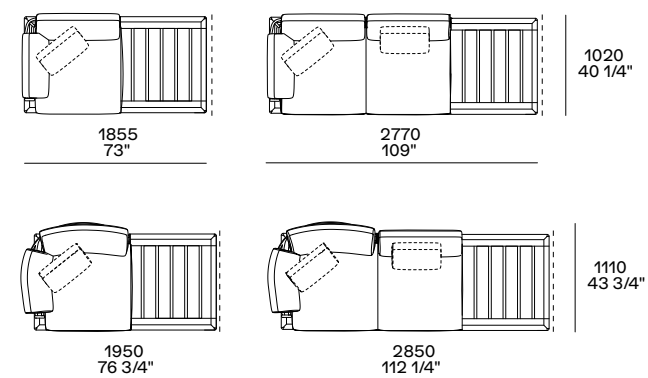

## Lt-rt corner end unit

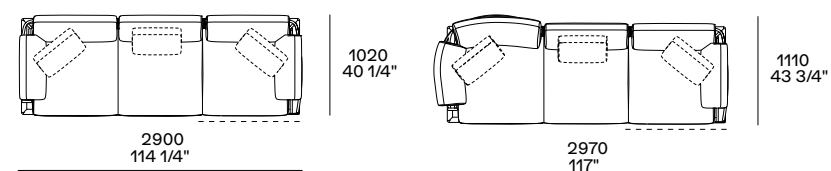

## Piano opzionale Optional placed-on top

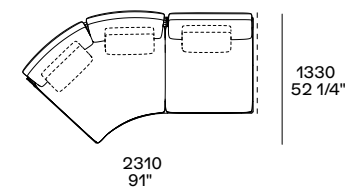
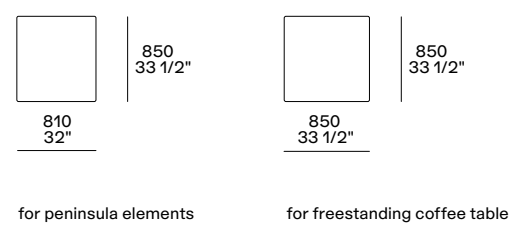

## Centrale Central unit

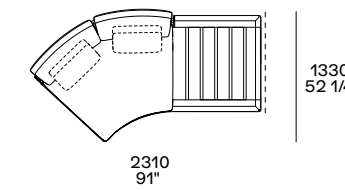
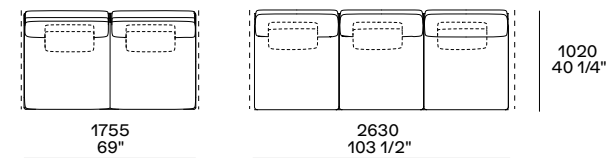

## Angolo sx-dx Lt-rt corner unit

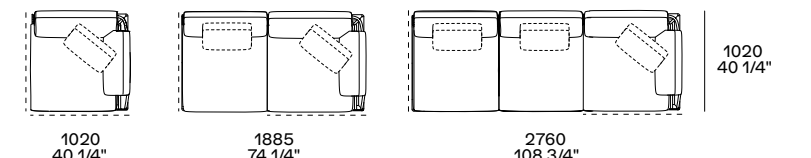

## Centrale penisola Peninsula central unit

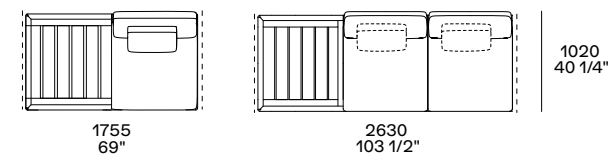

## Angolo penisola sx-dx Lt-rt peninsula corner unit

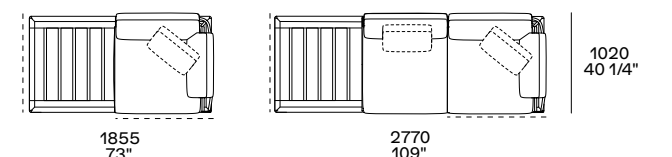

## Centrale inclinato Angled central unit

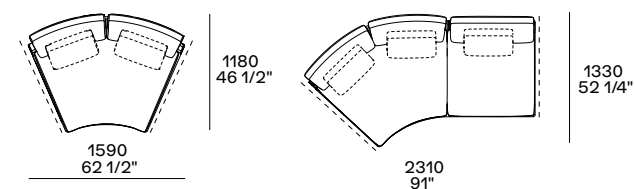

## Centrale penisola inclinato Angled peninsula central unit

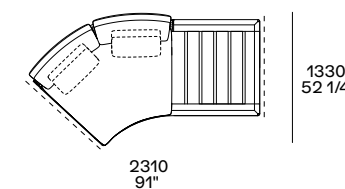

## Chaise longue Chaise longue

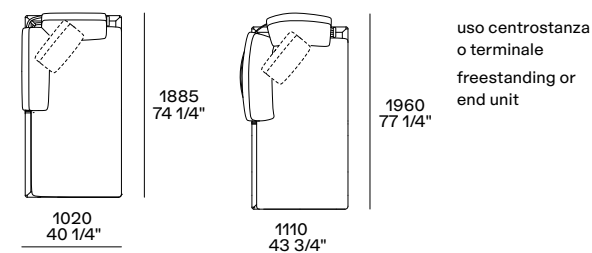

## Pouf centrostanza Freestanding pouf

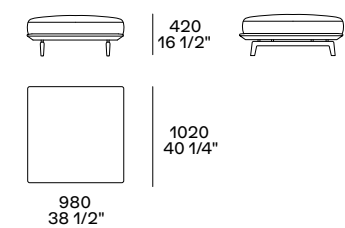

## Poltrona Armchair

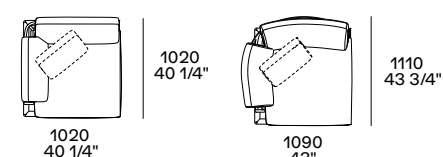

## Tavolino centrostanza Freestanding coffee table

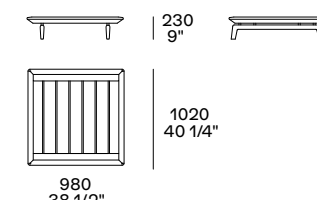

## Cuscino opzionale Optional cushion

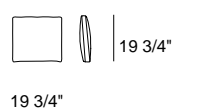



# PONTE COLLECTION

The Ponte collection draws its inspiration from the nautical world. Designed by Emmanuel Gallina, it was conceived as the perfect seat for gazing out at the sea. The armchairs and sofa rope backrest that enhances their lightness and elegance.





On this page: close up of the Ponte armchair with structure in solid teak and backrest in rope testa di moro, removable cover in fabric Karif 05 moka. On the previous pages: Ponte armchair with structure in solid teak and backrest in twisted rope naturale, removable cover in fabric Nashi 05 corda.





On this page: Ponte armchair with structure in solid teak and backrest in rope testa di moro, removable cover in fabric Karif 05 moka. On the next page: Ponte sofa with structure in solid teak and backrest in twisted rope naturale, removable cover in fabric Mojave 04 oceano, cushions in fabric Nashi 02 oceano. On the closing page: Ponte sofa with structure in solid teak and backrest in rope mattone, removable cover in fabric Mojave 01 corda, cushions in fabric Nashi 09 mattone.





PONTE

in corda nei colori mattone e testa di moro o in corda ritorta nel colore naturale. Cuscino seduta e schienale in poliestere riciclato PET con inserto in poliuretano. Cuscino opzionale in poliestere riciclato PET. Prerivestimento in fibra di poliestere. Rivestimento sfoderabile in tessuto.

Structure in solid teak with backrest in painted stainless steel tubular and covered with rope in the colours mattone and testa di moro or twisted rope in the colour naturale. Seat and back cushions in recycled PET polyester with a polyurethane insert. Optional lower back cushion in recycled PET polyester. Pre-cover in polyester fiber. Removable cover in fabric.

**Divano  
Sofa**

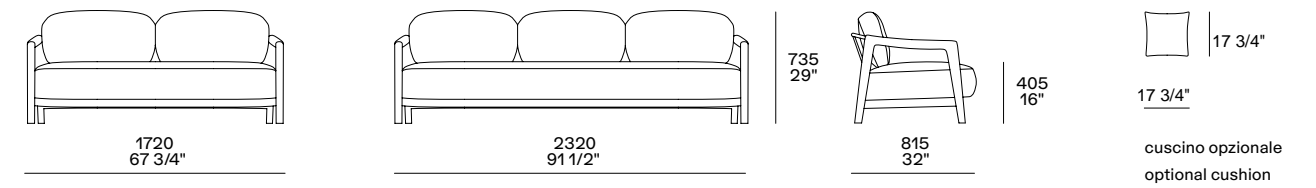

**Poltrona  
Armchair**

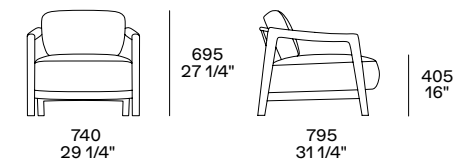



# REEF COFFEE TABLE

Reef is a collection of outdoor coffee tables inspired by rocks gently shaped by the sea. Crafted from concrete, they stand out for their raw, organic aesthetic that highlights the beauty of the material. The carefully curated colour palette is designed to pair beautifully with all outdoor furniture and fabrics.

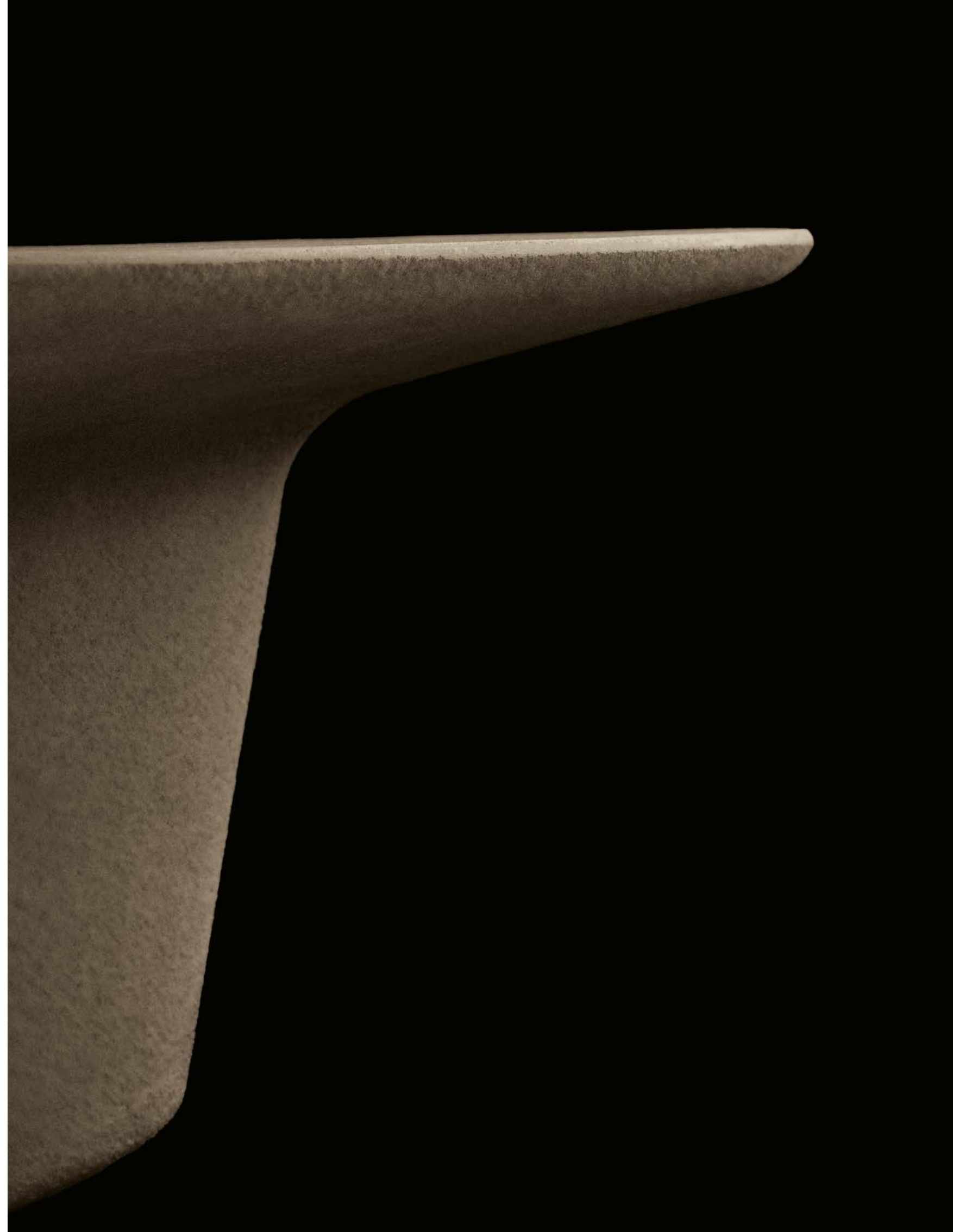



On this page: close up of the Reef coffee table in Cementoraw crema. On the previous page: Reef coffee tables in Cementoraw in the colours menta and crema. On the next page: Reef coffee tables in Cementoraw in the colours terracotta and crema.



# REEF

Tavolino in Cementoraw nei colori crema,

Coffee table in Cementoraw in the colours  
crema, menta and terracotta.

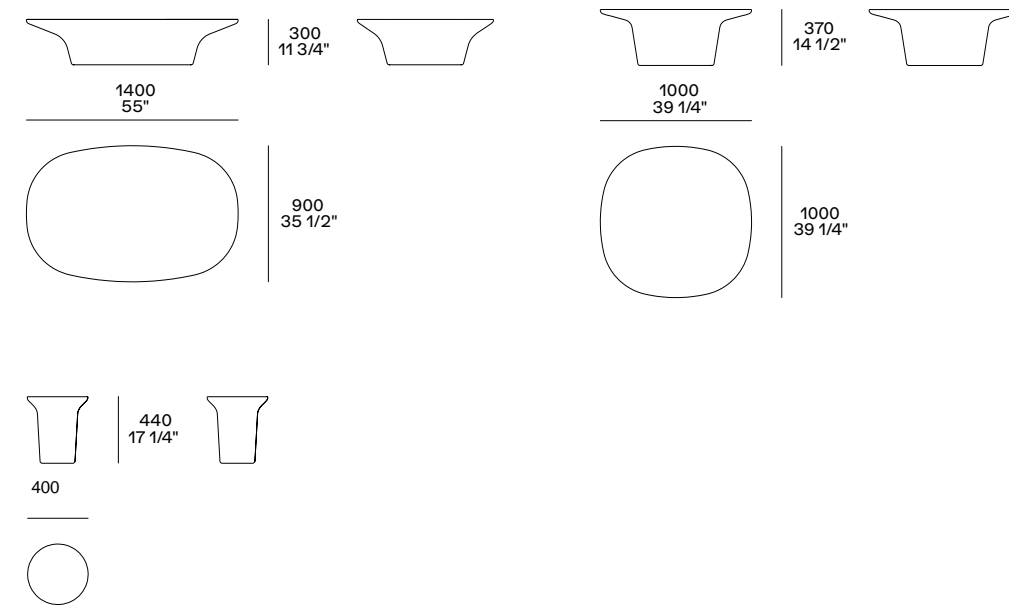

# ATOLL COFFEE TABLE

Atoll side table is a small collectible piece designed to elevate  
fined, artisanal touch to open-air environments in tune with  
the natural surroundings.





## ATOLL

Coffee table in mat glazed gres in the colours crema, menta and terracotta.

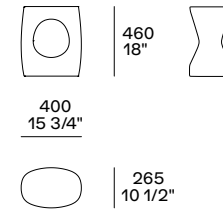

On this page Atoll coffee tables in mat glazed gres in the colours crema and menta, on the previous page in terracotta colour.

# DAMA COFFEE TABLE

A Plankfist classic, the Dama side table stands out for its essential design and versatility, making it a perfect fit for any setting-including outdoor spaces. This special outdoor edition





## DAMA

Tavolino in poliuretano rivestito  
in pietra spatolata nei colori arena  
e tortora.

Coffee table in polyurethane covered  
in spatula finish stone in the colours arena  
and tortora.

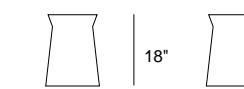

360 - 380  
14 1/4" - 15"



precedente nel colore tortora.

On this page Dama coffee tables in stone in the colours arena and  
tortora, on the previous page in tortora colour.

# HENRY TABLE

Emmanuel Gallina's iconic Henry table is reimagined for outdoor spaces through a complete transformation of materials. Its aluminum frame, featuring legs and a crossbar crafted using advanced die-casting technology, is paired with a teak or glazed stoneware top. The result is a perfectly smooth surface with a sophisticated, organic touch.

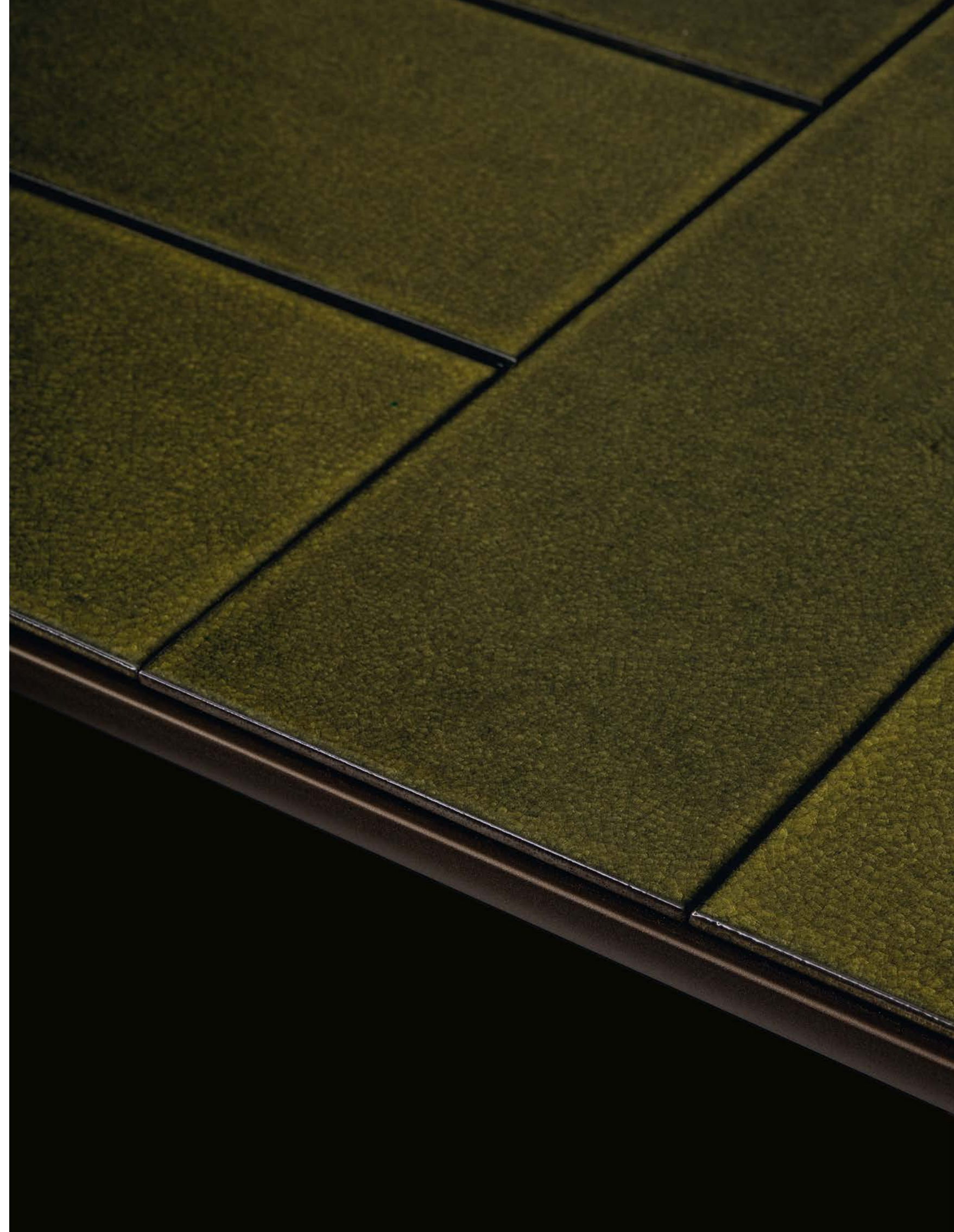





On this and on the next page: Henry table with structure in embossed painted aluminum casting colour oxid and top in solid teak. On the previous pages: Henry table with structure in embossed painted aluminum casting colour oxid and top in gres with cast glass colour menta.



On this and on the next page: Henry table with structure in embossed painted aluminum casting colour oxid and top in gres with cast glass colour terracotta.



# HENRY

Piano in massello di teak o in gres con vetro

casting in the colours sabbia and oxid.  
Top in solid teak or in gres with cast glass in  
the colours crema, menta and terracotta.

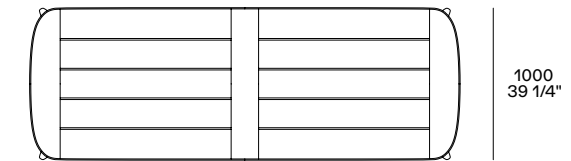
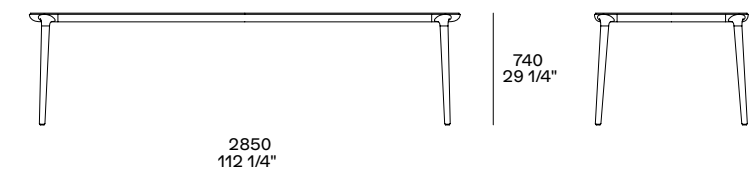
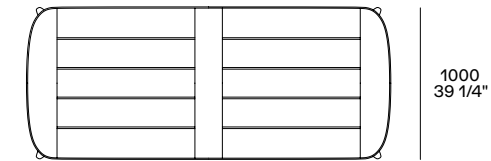
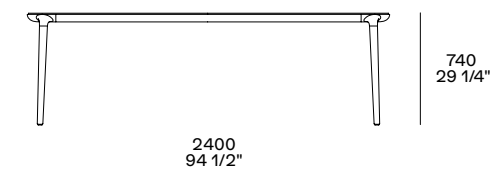
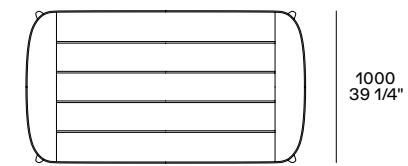
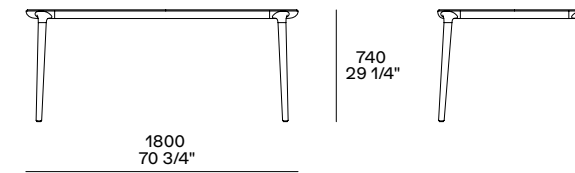



# MARINA CHAIR

outdoor e dato dallo schienale, disponibile in diverse tonalita

Marina channels the elegance and sophistication of Emmanuel Gallina's indoor seating into an outdoor chair. With its curved lines, enveloping form, and metal accents reminiscent of fine jewelry, it adds a sophisticated touch to open-air spaces. The defining outdoor element is the backrest, available in a range of tones to match with the rest of the collection.





On this and on the previous pages: Marina chair with structure in embossed painted colour oxid and backrest in large tape testa di moro colour, removable cover in fabric Karif 02 burro.

On this page: close up of the leg in embossed painted aluminum casting colour oxid. Next page: Marina chair with structure in embossed painted oxid and backrest in large tape testa di moro colour, removable cover in fabric Karif 02 burro.





## MARINA

Schienale in tubolare di acciaio inox verniciato e rivestito in fettuccia larga nei

Cuscino seduta e schienale in poliesterе riciclato PET con inserto in poliuretano. Prerivestimento in fibra di poliesterе. Rivestimento sfoderabile in tessuto.

in the colours sabbia and oxid. Tubular stainless steel backrest painted and covered with large tape in the colours mattone, testa di moro and naturale. Seat and backrest cushion in recycled PET polyester with polyurethane insert. Pre-cover in polyester fiber. Removable cover in fabric.

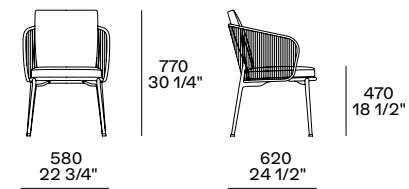

# SOORI DAY ARMCHAIR



outdoor collection. Like Soori Day Lounge, it features a rounded shape, a relaxed design, and an elegant woven backrest.





On this, on the previous and on the next page: Soori Day armchairs with structure in stainless steel, backrest covered in woven tape testa di moro, embossed painted base colour oxid. On the previous page: left, cover in removable fabric Karif 03 sabbia and backrest cushions in removable fabric Ghibli 04 sabbia; right, cover in removable fabric Nashi 05 corda. On this and on the next page: cover in removable fabric Nashi 05 corda and backrest cushions in removable fabric Mojave 01 corda.





## SOORI DAY

inox verniciato e rivestito in fettuccia intrecciata colore testa di moro.  
 Basamento in tubolare di acciaio inox verniciato goffrato nel colore oxid.  
 Piedini in materiale plastico.  
 Base seduta in poliuretano espanso monoquota. Cuscino seduta in poliester riciclato PET con inserto in poliuretano.  
 Cuscini schienale in poliester riciclato PET.  
 Prerivestimento in fibra di poliester.  
 Rivestimento sfoderabile in tessuto.

structure painted and covered in woven tape colour testa di moro.  
 Tubular stainless steel base embossed painted in colour oxid.  
 Feet in plastic material.  
 Seat base in single-density polyurethane foam. Seat cushion in recycled PET polyester with insert in polyurethane.  
 Backrest cushions in recycled PET polyester. Pre-cover in polyester fibre.  
 Removable cover in fabric.

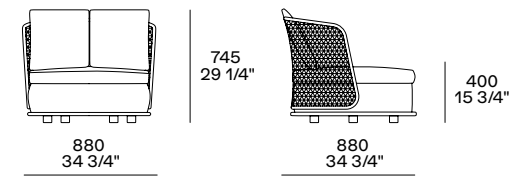



# SOORI COFFEE TABLE

outdoor perche, come i coffee table da interno, ha un'este-

Soori, a side table designed by Soo Chan, draws inspiration from the traditional vases of Bali. Available in various sizes and featuring a natural-toned stone finish, Soori is the perfect addition to any outdoor setting. Like indoor coffee tables, any piece in the collection.





On this page: close up of the Soori coffee table in stone arena colour.  
On the previous page: Soori coffee tables in stone in the colours arena  
and tortora. On the next page: Soori coffee tables in stone arena colour.

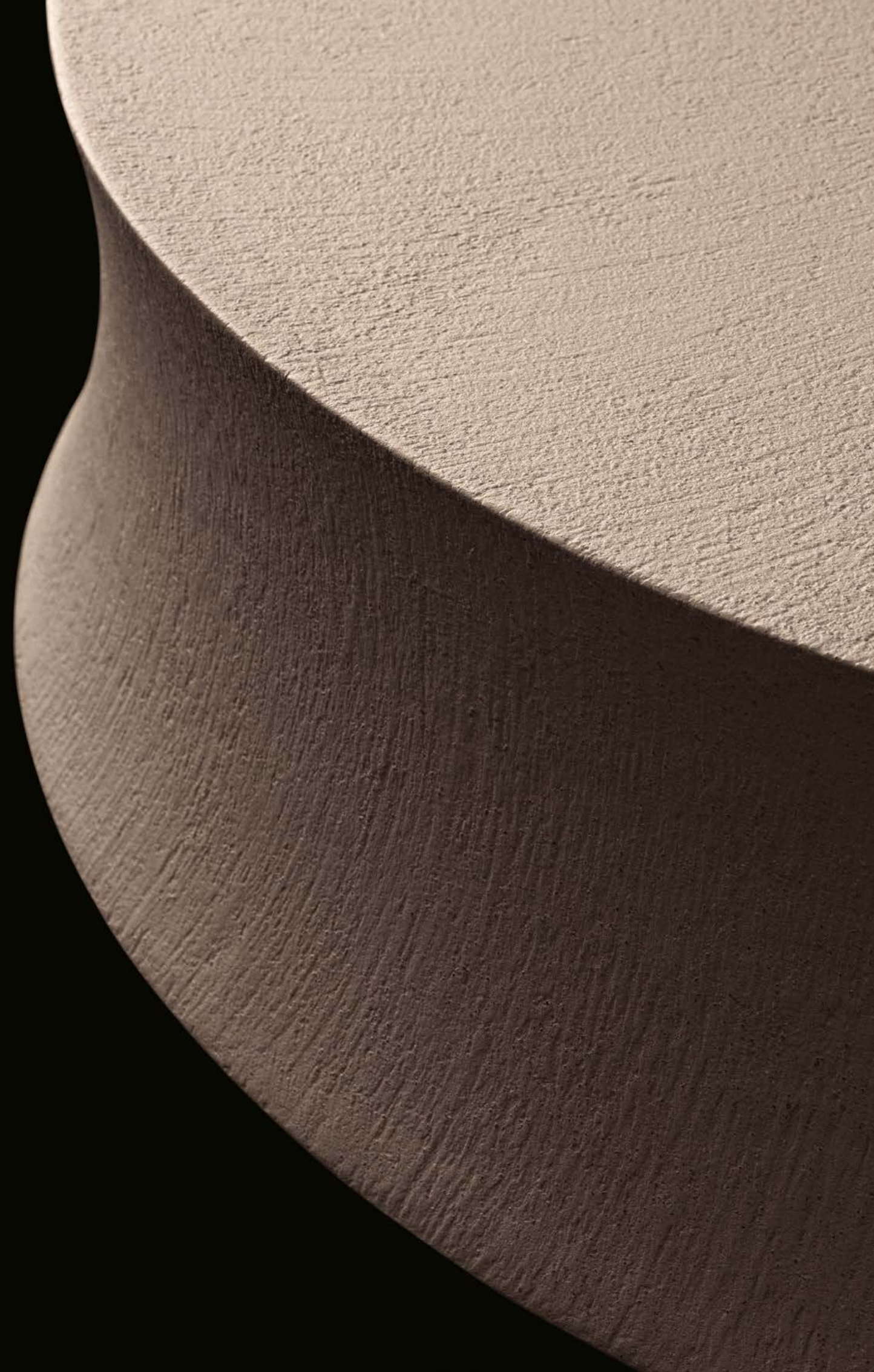



SOORI

in pietra spatolata nei colori arena e tortora.

resinata rivestita in pietra spatolata nei

covered in spatula finish stone in the colours arena and tortora.

Coffee tables 31 1/2"- 47 1/4" with resin-coated structure covered in spatula finish stone in the colours arena and tortora.

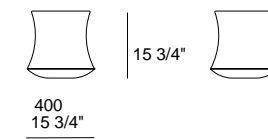
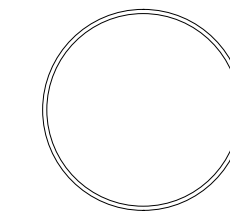
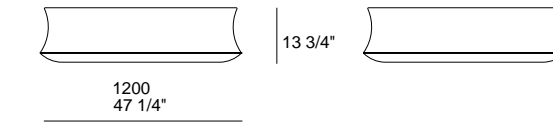
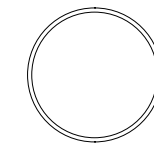
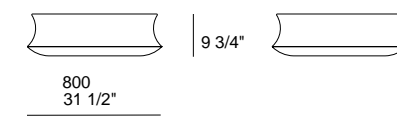



# NEW OUTDOOR FABRICS

Plankfist's outdoor fabric collection combines elegance with high performance. These fabrics, made entirely in Italy, offer exceptional durability and resistance, while maintaining their softness and understated elegance. New variations of boucle and textured weaves refine the existing selection, designed to provide visual and tactile continuity between indoor and outdoor spaces. Alongside the signature neutral palette, new tones have been introduced to complement the natural warmth of teak.

NUOVI TESSUTI OUTDOOR  
NEW OUTDOOR FABRICS

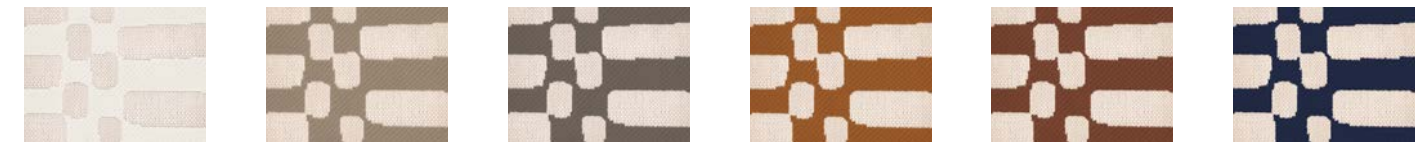

16 celadon



15 muschio

**Mojave**  
fabric cat. e

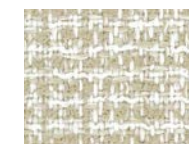

01 corda

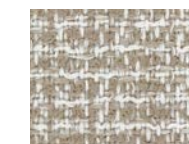

02 sabbia

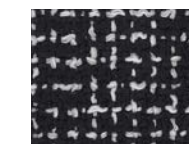

03 grafite



04 oceano

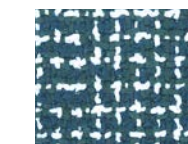

05 celadon

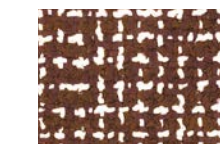

06 mattone



07 ruggine



08 muschio

**Sechura**  
fabric cat. e

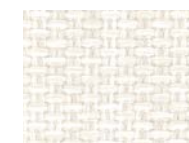

01 bianco

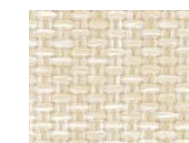

02 burro

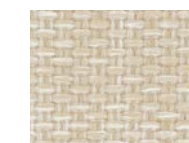

03 sabbia



04 corda



05 grafite



06 celadon

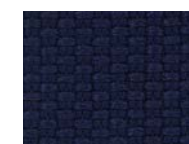

07 oceano



08 muschio



09 ruggine



10 mattone

**Nashi**  
outdoor fabric cat. g



01 neve

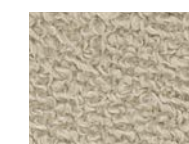

05 corda



04 sabbia

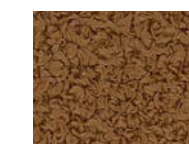

10 ruggine

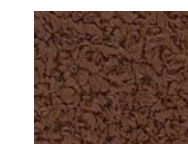

09 mattone



03 grafite

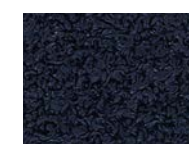

02 oceano



30 muschio

● news

Karakum - Mojave - Sechura - Nashi  
100% polipropilene riciclabile, certificato Oeko  
Tex - 100% recyclable polypropylene,  
Oeko Tex certified

OUTDOOR PROPOSALS

COMPOSITION 01	332
COMPOSITION 02	334
COMPOSITION 03	336
COMPOSITION 04	338
COMPOSITION 05	340
COMPOSITION 06	342



**COMPOSITION 01**

cuscini in tessuto Karakum 15 muschio e Mojave 08 muschio, base in gofrato oxid. Divano con piano in appoggio in gres con vetro colato menta. Tavolini Reef in Cementoraw menta e crema. Tappeto Kamir ecru.

Lagoon sofa and chaise longue in removable fabric Nashi 05 corda, cushions in fabric Karakum 15 muschio and Mojave 08 muschio, base in solid teak and backrest in twisted rope naturale, feet in embossed painted oxid. Sofa with placed-on top in gres with cast glass colour menta. Reef coffee tables in Cementoraw menta and crema. Carpet Kamir ecru.



**COMPOSITION 02**

suto Ghibli 01 tabacco e Karif 04 tabacco, base in massello di teak

centro, tavolini Reef in Cementoraw crema. Tavolini Azu in gres smaltato lucido bronzo. Tappeto Kamir ecru.

Lagoon sofa in removable fabric Karif 04 tabacco, cushions in fabric Ghibli 01 tabacco and Karif 04 tabacco, base in solid teak and backrest in twisted rope naturale, feet in embossed painted oxid. Ponte armchairs with structure in solid teak and backrest in twisted rope naturale, removable cover in fabric Karif 02 burro. In the center, Reef coffee tables in Cementoraw crema. Azu coffee tables in glossy glazed gres bronzo. Carpet Kamir ecru.



**COMPOSITION 03**

suto Karakum 11 grafite e Nashi 03 grafite, base in massello di teak

Dama in pietra nel colore tortora. Tappeto Kamir cenere.

Lagoon sofa in removable fabric Mojave 03 grafite, cushions in fabric Karakum 11 grafite and Nashi 03 grafite, base in solid teak and backrest in rope testa di moro, feet in embossed painted oxid. Lagoon armchairs in removable fabric Sechura 05 grafite, cushions in fabric Karakum 11 grafite, base in solid teak and backrest in rope testa di moro, feet in embossed painted oxid. In the center, Lagoon coffee tables in solid teak, feet in embossed painted oxid. Dama coffee tables in stone tortora colour. Carpet Kamir cenere.



**COMPOSITION 04**

to Karakum 13 mattone e Nashi 09 mattone, base in massello di teak

Lagoon in massello di teak con piano in appoggio in gres con vetro co-

Lagoon sofas in removable fabric Mojave 01 corda, cushions in fabric Karakum 13 mattone and Nashi 09 mattone, base in solid teak and backrest in rope mattone, feet in embossed painted oxid. Ponte arm-chairs with structure in solid teak and backrest in rope mattone, removable cover in fabric Nashi 05 corda. In the center, Lagoon coffee tables in solid teak with placed-on top in gres with cast glass colour terracotta, feet in embossed painted oxid. Soori coffee tables in stone arena colour. Carpet Kamir corda.



**COMPOSITION 05**

ro, cuscini in tessuto Mojave 01 corda e Karakum 12 corda, base in

01 corda. Al centro, tavolini Reef in Cementoraw terracotta e crema.

Lagoon sofa and chaise longue in removable fabric Karif 02 burro, cushions in fabric Mojave 01 corda and Karakum 12 corda, base in solid teak and backrest in rope testa di moro, feet in embossed painted oxid. Ponte armchairs with structure in solid teak and backrest in rope testa di moro, removable cover in fabric Mojave 01 corda. In the center, Reef coffee tables in Cementoraw terracotta and crema. Atoll coffee tables in mat glazed gres crema. Carpet Kamir ecru.



**COMPOSITION 06**

tessuto Nashi 02 oceano e Karakum 10 oceano, base in massello di  
trecciato non sfoderabile. Al centro, tavolini Reef in Cementoraw cre-

Lagoon sofa in removable fabric Mojave 04 oceano, cushions in fabric Nashi 02 oceano and Karakum 10 oceano, base in solid teak and backrest in twisted rope naturale, feet in embossed painted oxid. Le Club armchairs with cover in Libeccio ecru, non removable woven fabric. In the center, Reef coffee tables in Cementoraw crema. Atoll coffee tables in mat glazed gres crema. Carpet Kamir ecru.



FINITURE OUTDOOR  
OUTDOOR FINISHINGS

**Massello**  
**Solid wood**



iroko tinto nero  
black stained iroko



teak ●

**Gres with cast glass**



crema ●



menta ●



terracotta ●

**Pietra lavica**  
**Lava stone**



roccia



nera

**Lava stone with glass decoration**

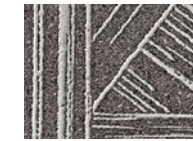

roccia



nera

**Pietra spatolata**  
**Spatula finish stone**



arena ●



tortora ●

**EVA (espanso vinilico acetato)**  
**EVA (expanded vinyl acetate)**



ghiaccio



nocciola



testa di moro



oliva

**Parti metalliche**  
**Metal parts**



sabbia  
verniciato gofrato  
embossed painted



oxid  
verniciato gofrato  
embossed painted ●

**Corda ritorta**  
**Twisted rope**



naturale ●



testa di moro

**Gres smaltato lucido**  
**Glossy glazed gres**



crema



salvia

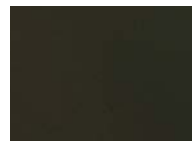

bronzo

**Gres smaltato opaco**  
**Mat glazed gres**

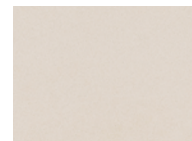

crema ●



menta ●



terracotta ●

**Corda**  
**Rope**



sabbia

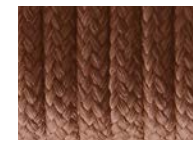

mattone



testa di moro

**Fettuccia larga**  
**Large tape**



naturale ●

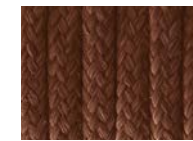

mattone ●



testa di moro ●

**Cementoskin**  
**Cementoskin**

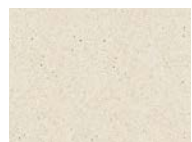

crema



tortora



grafite

**Cementoraw**  
**Cementoraw**

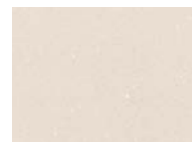

crema ●

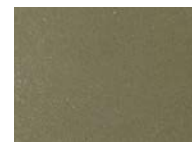

menta ●



terracotta ●

**Libeccio\***  
**woven fabric**

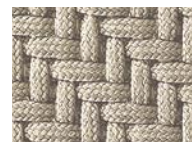

ectu



visone



notte

poltrona Le Club outdoor  
available only for Le Club  
outdoor armchair

**Mat and glossy glazed gres**



sabbia



grafite

**Vetrofusione**  
**Fused glass**



bronzo  
bronze



fume  
fume

**Land**  
**kitchen**



alluminio laccato  
lacquered aluminium  
structure and sides



Inalco MDi  
11 carbone  
fronts and covers



Inalco MDi  
10 porfido beige  
fronts and covers

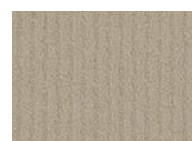

Inalco MDi  
12 camel lines  
fronts and covers



acciaio - steel  
barbecue and  
accessories

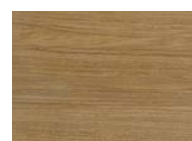

massello di teak  
solid teak  
top and accessories

**Tessuti**  
**Fabrics**



mistral cat. d  
5 colori - colours



shamal cat. d  
11 colori - colours



karakum cat. g  
8 colori - colours ●



8 colori - colours ●



10 colori - colours ●

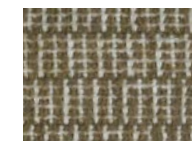

bris cat. g  
4 colori - colours

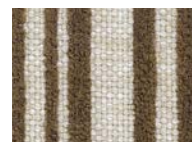

ghibli cat. g  
4 colori - colours

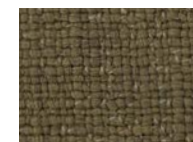

karif cat. g  
5 colori - colours



merak cat. g  
8 colori - colours



nashi cat. g  
8 colori - colours ●



zephiros cat. m  
7 colori - colours

● news



All the Plankfist collections are manufactured 100% in Italy using **top-class components and materials.**

Plankfist si riserva il diritto di apportare, senza preavviso, ogni modifica e disegni presenti in questo stampato hanno scopo divulgativo: per ogni

Plankfist reserves the rights at all time to apply modifications for the functional or qualitative improvement of its products. Texts and drawings present in this brochure have a divulgative purpose: for every technical and dimensional aspect please refer to the company's price lists and their relative updatings. The colour and material samples have an indicative value.

**Creative Direction**  
Apartamento Studios

**Graphic Design**  
Apartamento Studios

**Still Life Photography**  
Silvia Orlandi

1st edition April 2025  
cod. 140/R1/2025



TWO THOUSAND TWENTY FIVE

PLANKFIST VENTURES PRIVATE LIMITED  
Hi Lite Business Park, Flat Nos. 2/1149/1-86 & 87, Iringallur Road  
Kozhikode, Kerala, India - 673014  
Phone: +91 85902 77688  
Email: [hello@plankfist.com](mailto:hello@plankfist.com) | [sales.plankfist@gmail.com](mailto:sales.plankfist@gmail.com)  
Website: [plankfist.com](http://plankfist.com)